

 **FABER**
AIR MATTERS

2019 COLLECTION



The pioneers of the
domestic cooker hood..

The performance shown in this catalogue is declared in accordance with the new Code of Conduct signed by the most qualified European manufacturers members of CECED (European Committee of Domestic Equipment Manufacturers), a strict code for transparency which establishes clear rules to measure air flow and noise level for hoods, common to all cooker hoods manufacturers:

- air capacity according to IEC/EN 61591 method
(with the hood fitted using a ducting pipe)
- noise level according to IEC/EN 60704-3 method (sound power)

FINISHES

AM/X	metal aluminium/Stainless steel handle
BK GLOSS	black gloss
BK	black
BK GLASS/A	black glass/aluminium
CG	country grey
CI	cast iron
CT	cross titanium
DG	dark grey
DG/C	dark grey/concrete
DGC	dark grey concrete
LG	light grey
LG/X	light grey/Stainless steel handle
OB	old brass
OC	old copper
OM	old metal
SS	black body/Stainless steel
strip	
WG	warm gray
WH	white
WH MATT/TS	white matt/tibetan Silver
WW	warm white
X	Stainless steel
X/OM	Stainless steel/old metal
X/V	Stainless steel/glass

PERFORMANCE

SPEED	Speed
M³/H	Air capacity IEC point
PA	Pressure
W	Input
dB(A)	Noise level

IMPORTANT NOTICE

All Faber hoods should be fitted by a qualified technician.

Reliability is a constant characteristic of all FABER products.

You might not see it, but it permeates your kitchen immediately.

It becomes easier to appreciate with time, a certainty, a guarantee. When everything is working as it should, home is a more relaxing place. When the air is pure and clean, home becomes a place of true wellbeing. That's what reliability means to us: making life better for years to come.

RECORDS IN EXCELLENCE

- The first **ISO 9001** Quality Certification in the field of kitchen hoods.
- **SGS Certificate of Excellence no.001**: a worldwide first.
- Integrated Management System for Quality (**ISO 9001:2015**), Occupational Health and Safety (**OHSAS 18001**) and the Environment (**ISO 14001**) certified by SGS.
- Products conforming to the strictest safety requirements and to standards **EN 61591** and **EN 60704-3**, tested in an authorised in-house laboratory, certified and guaranteed by leading international bodies.

IMQ	The Italian Quality Mark
CE	The EU Safety Mark
SEMKO	International Safety Certification by Intertek ETL
UL	The Quality Mark for the USA and Canada
CCC	The Chinese Quality Mark

ENERGY LABEL FOR CLEARER SAVINGS.

Energy Efficiency Class: hoods with the highest ratings (A++, A+, A) consume less and are more respectful of the environment (green colour).

Annual Electricity

Consumption: calculated for standard hood functioning times (60 minutes of suction and 120 minutes of lighting a day).

Fluid-dynamic efficiency:

reveals the quality and power of the hood: efficiency rises as suction power increases or energy consumption decreases.

Lighting efficiency: this indicates how much light the hood produces for the energy it consumes; for the same lighting power, more light-efficient hoods consume less.

Filter efficiency: indicates the filter's capacity to capture grease.

Noise level: measured in dB at the hood's maximum fan speed (not boost).

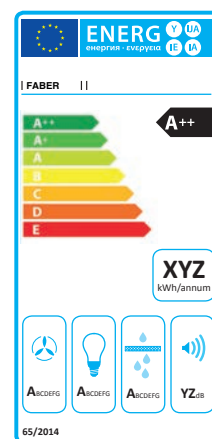

A vision of global reach.



HEADQUARTERS
Italy

A VISION OF GLOBAL REACH.

FABER has a lot in common with air... both are present all over the world.

Air has always been our chosen material. Now the world is our home. So it's only natural we should want to improve them both. Installing a kitchen hood is an easy way to improve the air in your home, of course, but only thanks to Faber. After all, we invented the kitchen hood, and we are making them better every day to provide our customers with the ultimate performance, quality and comfort. **Aspiring to a better world through leadership. Everywhere, every day.**

INVESTING IN THE WORLD

Always growing, to serve more people.

THINKING LONG TERM

All-round competence: automation, robotics, IT, total quality.

INNOVATING CONTINUOUSLY

Engineering research, advanced solutions, living benefits.

DESIGNING THE FUTURE

Ergonomics, design, functionality, comfort, style and wellbeing for the home.

ISLAND HOODS
10



Arkea Plus 11



NEW Belle / Belle Plus 12



NEW Céline / Céline Plus 14



NEW Glow / Glow Plus 18



Lybra Plus 21



Nest Plus 22



NEW Odette / Odette Plus 23



Pareo Plus 25



Vanilla Plus 26



Zoom Plus 27



Corinthia Isola 28



Cylindra Isola 30



Cylindra Isola Plus Concrete 31



T-Light Isola 32



Stilo Isola / SP 34

CEILING HOODS
35



Heaven 2.0 36



Heaven Compact 37



Heaven Glass 2.0 39



Heaven Glass 2.0 Slim/Heaven 2.0 Slim 40



Heaven Lite Glass / Heaven Lite 42



High-Light 43



Skylift 45



Skypad 2.0 48



Fabula Plus 51



NEW Galileo 52



Chloè 58



City 62



Cocktail 63



Cocktail XS 65



Daisy B 66



NEW Glam-Fit 67



NEW Grexia 70



Jolie 72



Lithos 74



Northia 75



NEW Onyx-T 76



NEW Pyana 79



Stilo EV8 81



Talika 83



Thalia 86



NEW Tweet 88



Veil 90



Vanity 92



Ilma 95



In-Light 98



In-Nova Premium 101



In-Nova Smart 102



Inca Lux 2.0 103



Inca Lux Glass 104



NEW Inca Smart ICH 105



Maxima 106



Victory 2.0 107



FCH63 110



FCH64 111



FCH83 112



FCH84 113

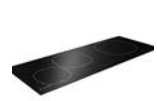

FCH93 114



ACCESSORIES
118

The technology behind the hood.



pag. 8



pag. 82



pag. 94

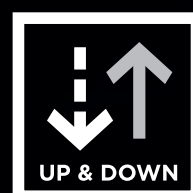

pag. 7

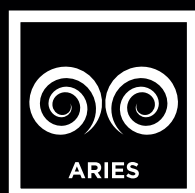

pag. 78



pag. 77

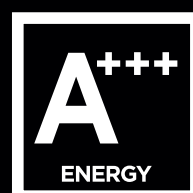

pag. 6

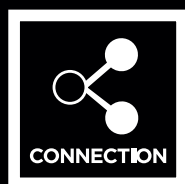

pag. 109



pag. 100

Advanced technology for real life benefits.

BRUSHLESS



The brushless motor guarantees considerable energy saving coupled with high extraction efficacy. It is the most silent motor on the market and its performance remains stable in any usage condition.

ENERGY DIFFUSER



Energy Diffuser: it reduces noise up to 3dB(A) and higher hood efficiency by 30% even in the presence of long air outlet.

DOUBLE ASPIRATION



Double extraction is derived from the overlapping of two glasses in vertical hoods, ensuring greater hood effectiveness.

BOOST



FABER introduced Boost suction some time ago. Now we bring you Double Boost! This additional increase in power gives your hood a total of 5 suction speeds. Double Boost has the power to eliminate even the most persistent steam and odours in just a few minutes.

SPEED I



Intensive speed: function which activates maximum aspiration for 6 minutes to meet special cooking needs.

ANTI TOUCH



Anti-fingerprint steel
Special anti-fingerprint steel for a perfectly clean hood and a steel surface free of annoying marks.

DELAY 30



Delayed switch-off: allows automatic delayed switching off of the motor to complete elimination of residual odours.

PERIMETER ASPIRATION

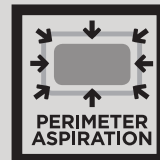

25% less* perceived noise. Perimeter suction exploits the Venturi effect to accelerate the air flow through a narrow gap. The air slows down again once inside the hood for more efficient extraction.

*Equivalent to a reduction of 3 dB(A) according to EN 60704-3.

HOUR 24

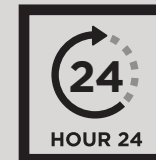

Key 24: function which allows the hood to be switched on for 24 hours a day for continuous air renewal with a level of noise that is imperceptible.

WATERPROOF



Any liquid spilled during cooking flows directly into a suction grille and is collected in an automatically drained tray under the hood, small enough to leave space for a utensil drawer.

REAR OUTLET



The rear air outlet available with many FABER hoods allows fumes to be channelled to the rear instead of upwards. This eliminates the need for an upper duct, freeing up useful space above the hood.

FILTER ALARM



Filter saturation alarm: warns you when it is time to clean the anti-grease filter or substitute the anti-odour filter.

COMFORT LIGHT



Courtesy light: reduced hood light intensity with the simple press of a button. Thanks to its low level of energy consumption, the courtesy light can be left on for long periods of time.

LIGHT DIMMER

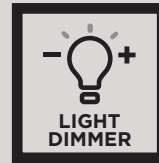

Dimmer light: adjusts hood courtesy light with the simple press of a button to meet all your kitchen needs.

NEW REMOTE CONTROL TECHNOLOGY. For a user-friendly kitchen.

With the new remote control design you can switch the hood on and off, adjust extraction power and light intensity and set the timer too. The remote control contains a magnet which lets you attach it to the hood when not needed, so that you always know where to find it.

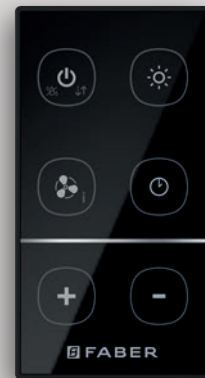

GREEN INNOVATION. Imagine a future of pure, fresh air.

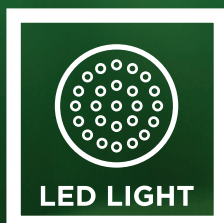
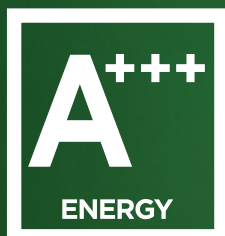

ENERGY EFFICIENCY CLASS A++, A+++

The energy efficiency class of a kitchen hood depends on the consumption of its fan motor, filter system and lighting. Needless to say, FABER hoods are in the highest efficiency classes. That means they deliver maximum performance for minimum consumption. Galileo, FABER's new hob extractor, exceeds all expectations and achieves the ultimate A+++ rating.

EVO BLOWER, THE EVOLUTION OF SILENCE.

All FABER hoods incorporate highly evolved blowers. This means exceptional performance in terms of efficiency, consumption, silence and effectiveness, even with long extraction ducts.

LED light FOR A BRIGHTER VIEW.

For the first time ever, all the hoods in the FABER 2018 collection incorporate LED lighting technology. Smart lighting for a naturally brighter future, LED units consume next to nothing and produce a pleasantly natural light that ensures perfect visibility without altering colours.

UP & DOWN TECHNOLOGY.

UP & DOWN: MOBILE LIGHT FOR YOUR KITCHEN.

The beauty of F-LIGHT hoods is that they don't just hang there. While raising the tone of any kitchen, their real ambition is to descend and be seen, to provide the light needed for perfect visibility. DOWN: the hood descends to illuminate the hob and ensure maximum extraction efficiency. UP: the hood returns to the ceiling to form an elegant light fitting. And FABER's brand-new remote control makes movement easy.



EXCLUSIVE TECHNOLOGY

F-LIGHT: MOVING IN CLASS A.

A ENERGY EFFICIENCY

All F-LIGHT models move silently, and this is clear proof of their quality, but there's more. Their energy efficiency places them in a class of their own while bringing comfort to your kitchen.

LED RING

FABER's new F-LIGHT hoods also feature a glass panel with a unique ring of light provided by a circular LED. This bright idea provides pleasant, effective illumination, improves the look of your hob and ensures visibility over the cooking area.

AIRLANE TECHNOLOGY.

Superb extraction through an invisible duct.



ANOTHER STEP FORWARD FROM FABER'S F-LIGHT HOODS.

The Plus versions (with UP&DOWN) of FABER's latest F-LIGHT hoods can now do without a conventional duct even in ducted mode: the duct is completely invisible thanks to AIRLANE TECHNOLOGY that guarantees purer air and better performance in energy class A.



AIRLANE
TECHNOLOGY

PURE POWER MAKES NO NOISE. IT WORKS IN SECRET.

With AIRLANE TECHNOLOGY, a second fan in the false ceiling switches on automatically along with the hood. As soon as fumes and steam emerge from the hood's top grill, they enter a rising vortex that is immediately captured and extracted by the overhead fan through a grill directly above that of the hood. The ascending vortex also draws in fumes from further away, purifying the air throughout the kitchen and delivering unrivalled comfort.

REAL POWER MAKES NO NOISE. IT KEEPS THE SECRET.

A second fan unit is hidden in just 30 cm of false ceiling thanks to the AIRLANE kit. At the time of installation, this can be connected to an outdoor air outlet in any of four different positions. The duct between the two remains completely invisible inside the home.



A second fan unit is hidden in just 30 cm of false ceiling

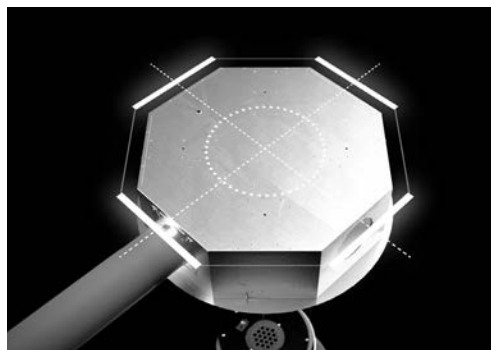

4 Different external outlet positions



KIT AIRLANE TECHNOLOGY

KIT AIRLANE TECHNOLOGY cod. 112.0542.875

FEATURES

Finish

· Stainless steel

Ø of air outlet

150 mm

Width

840 mm

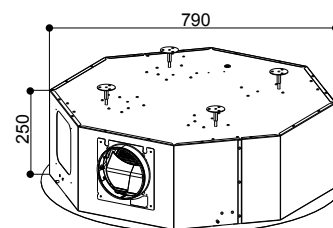
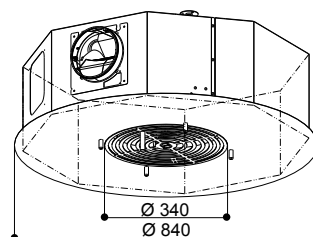

THE AIRLANE KIT REPLACES THE CHIMNEY/DUCT NEEDED FOR SUSPENDED INSTALLATION AS A DUCTED HOOD.

ISLAND HOODS

1. Island F-Light Hoods
2. Island Hoods

Island workstations provide a focal point in the kitchen. This selection of beautiful Faber island hoods will both enhance this space and provide effective extraction.

Unique colour changing mood lamp and extractor.

The hood can also be operated by using the controls on a Faber hob

The hood can also be operated by using the controls on a Faber hob

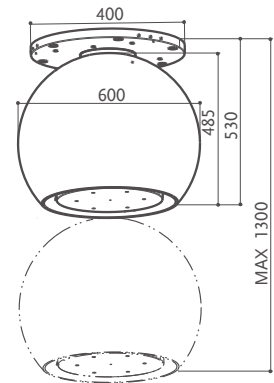

ARKEA PLUS

ARKEA PLUS cod. 345.0492.562



HOOD&HOB

FEATURES	PERFORMANCE	ACCESSORIES
Finish • Stainless steel / polycarbonate	Speed 1 2 3 INT	Cod. 112.0158.127
Controls Electronic	Air capacity IEC point 270 340 430 620	FHP8 High Performance Charcoal filter
Lighting Micro LED / Ambient back-lighting lamps	Pressure - - - -	Cod. 112.0185.278
Grease filter Cassettes dishwasher safe	Input 120 150 190 270	FLL8 Long Lasting Charcoal filter
Ø of air outlet 150 mm	Noise level 52 58 64 71	
Width 600 mm		
Energy class -*		



Arkea features LED RGB ambience lighting, allowing you to choose your favourite colour or alternate all colours in a loop.



* Data not declared, as the model is exclusively available as a recirculating hood.

BELLE PLUS



Featuring the latest in island hood technology finished in beautiful warm colours.



Gold / Warm Dark Grey Matt



Grey Matt / Warm Dark Grey Matt

The hood can also be operated by using the controls on a Faber hob

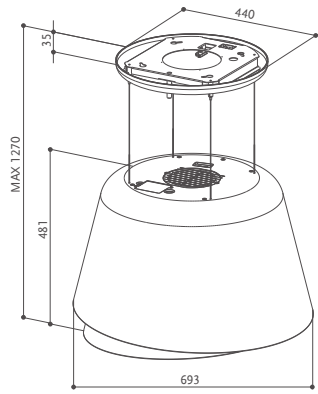

BELLE PLUS



BELLE

BELLE PLUS GREY MATT/WARM DG MATT cod. 345.0541.067
 BELLE PLUS GOLD/WARM DG MATT cod. 345.0541.068

BELLE GREY MATT/WARM DG MATT cod. 345.0541.065
 BELLE GOLD/WARM DG MATT cod. 345.0541.066

(optional)		HOOD&HOB BELLE PLUS								

FEATURES	PERFORMANCE	ACCESSORIES
Finish • Grey matt / Warm dark grey matt • Gold / Warm dark grey matt	Speed 1 2 3 INT Air capacity IEC point 240 300 430 640 Pressure 280 410 510 540 Input 95 125 185 230 Noise level 51 54 58 68	Cod. 112.0158.127 FHP8 High Performance Charcoal filter Cod. 112.0185.278 FLL8 Long Lasting Charcoal filter Cod. 112.0542.875 Airplane ducting kit
Controls Touch control		
Lighting Perimetral LED light		
Grease filter Cassettes dishwasher safe		
Ø of air outlet 150 mm		
Width 695 mm		
Energy class A		



CÈLINE PLUS



MY
WHITE
BOOK

MY
BLACK
BOOK



**BRAND
NEW**

**Simple, stylish,
subtle, but
with the latest
in extraction
technology.**



Country Grey Matt



Warm White / Country Grey Matt



THE CONICAL HOOD. A MODERN CLASSIC.

A thin line of Stainless steel embellishes the top part of this original, conical hood, which is also available with a bottom section in a different finish.

The contemporary, essential design of Céline is made even more striking by Up& Down technology. The hood can be raised to the ceiling when not in use and lowered again whenever its extraordinary performance is needed. Céline comes in a choice of matt country grey and warm white.

The hood can also be operated by using the controls on a Faber hob

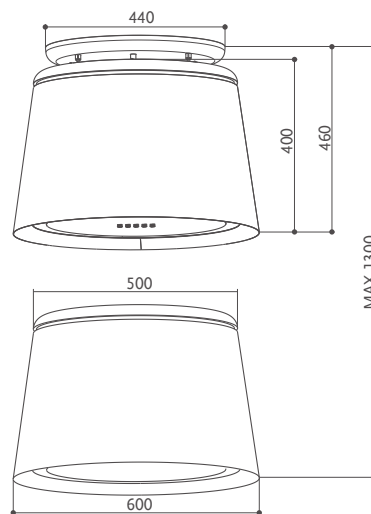

CÉLINE PLUS

CÉLINE PLUS CG MATT cod. 345.0541.063
CÉLINE PLUS WW/CG MATT cod. 345.0541.064

CÉLINE

CÉLINE CG MATT cod. 345.0541.061
CÉLINE WW/CG MATT cod. 345.0541.062



FEATURES	PERFORMANCE	ACCESSORIES
Finish • Country grey matt • Warm white / Country grey matt	Speed 1 2 3 INT Air capacity IEC point 240 300 430 640 Pressure 280 410 510 540 Input 95 125 185 230 Noise level 51 54 58 68	Cod. 112.0158.127 FHP8 High Performance Charcoal filter Cod. 112.0185.278 FLL8 Long Lasting Charcoal filter Cod. 112.0542.875 Airlane ducting kit
Controls Touch control		
Lighting Perimetral LED light		
Grease filter Cassettes dishwasher safe		
Ø of air outlet 150 mm		
Width 600 mm		
Energy class A		

GLOW PLUS

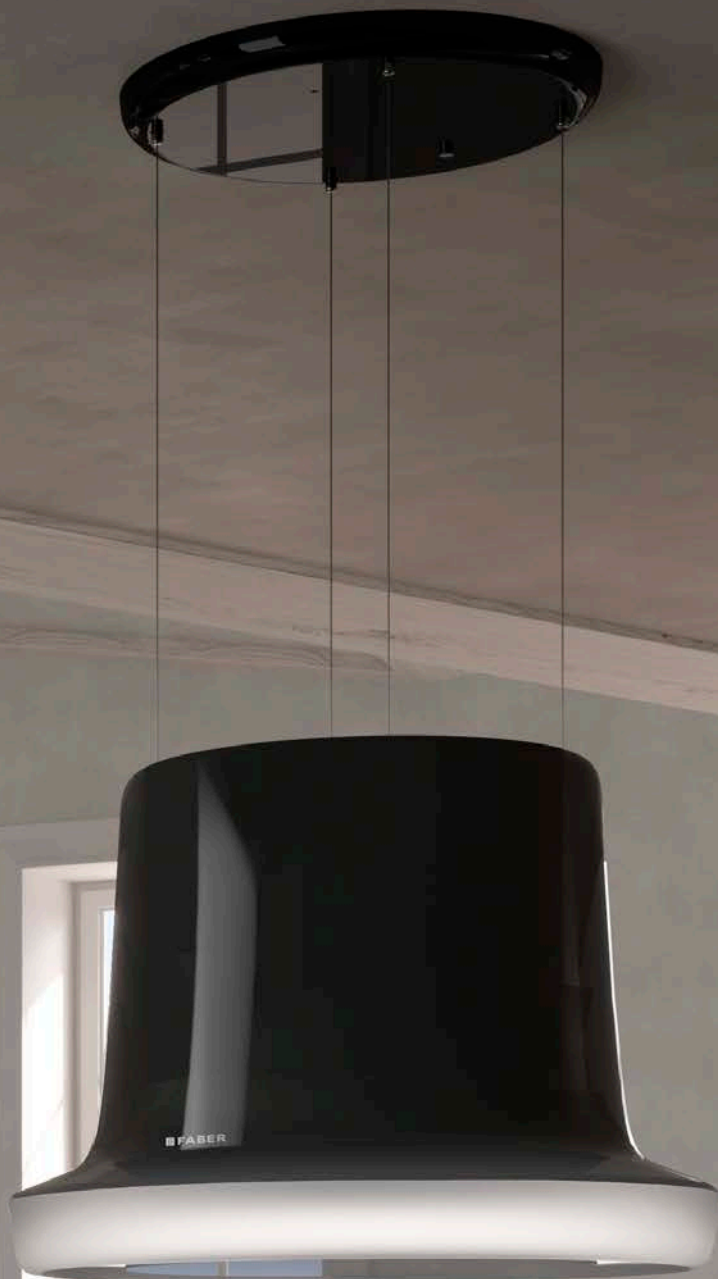



**BRAND
NEW**

The latest perimeter lighting design creates a real statement piece.

Black Gloss



White



A TRULY BRIGHT IDEA

The circular band around the base of this striking cylindrical hood illuminates the kitchen and is both striking yet refined; finished in white and black nickel gloss. Impressive style complemented by the ultimate in Faber performance.

The hood can also be operated by using the controls on a Faber hob

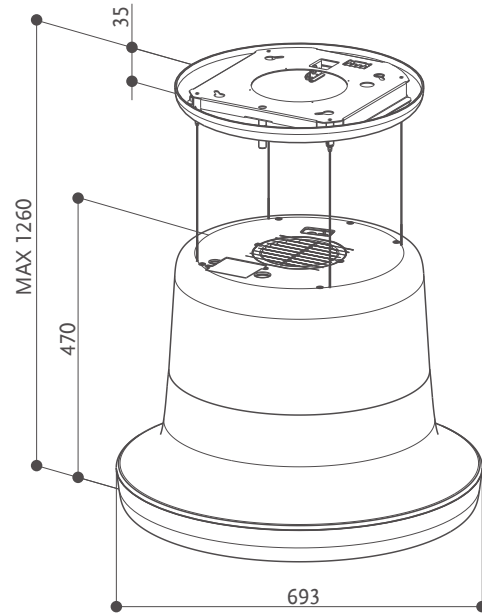

GLOW PLUS



GLOW PLUS BK GLOSS cod. 345.0541.007
GLOW PLUS WH cod. 345.0541.008

GLOW

GLOW BK GLOSS cod. 345.0541.005
GLOW WH cod. 345.0541.006



FEATURES	PERFORMANCE	ACCESSORIES
Finish · Black gloss · White	Speed 1 2 3 INT Air capacity IEC point 240 300 430 640 Pressure 280 410 510 540	Cod. 112.0158.127 FHP8 High Performance Charcoal filter
Controls Touch control	Input 95 125 185 230 Noise level 51 54 58 68	Cod. 112.0185.278 FLL8 Long Lasting Charcoal filter
Lighting Perimetral LED light		Cod. 112.0542.875 Airlane ducting kit
Grease filter Cassettes dishwasher safe		
Ø of air outlet 150 mm		
Width 695 mm		
Energy class A		



Zebra - Striped Glass
Limited Edition



Lybra, ducted version



A cubic up-and-down hood gives a modern twist to the kitchen.

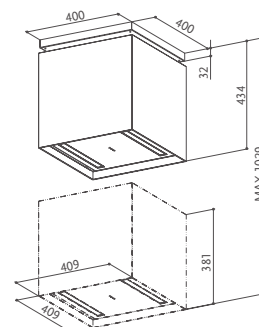

LYBRA PLUS

LYBRA PLUS cod. 110.0255.507

LYBRA PLUS BLACK STRIPED cod. 110.0393.250

The hood can also be operated by using the controls on a Faber hob



HOOD&HOB

FEATURES	PERFORMANCE	ACCESSORIES
Finish • Stainless steel / glass • Stainless steel / Zebra-striped glass	Speed 1 2 3 INT	Cod. 112.0158.127
Controls Electronic	Air capacity IEC point 270 340 430 620	FHP8 High Performance Charcoal filter
Lighting 2 LED lights	Pressure 400 460 530 560	Cod. 112.0169.216
Grease filter Cassettes dishwasher safe	Input 120 150 190 270	F-LIGHT ducting kit
Ø of air outlet 150 mm	Noise level 52 58 64 71	Cod. 112.0185.278
Width 409 mm		FLL8 Long Lasting Charcoal filter
Energy class A		



Nest, ducted version

Free form glass gives a chandelier effect to this beautiful cooker hood.

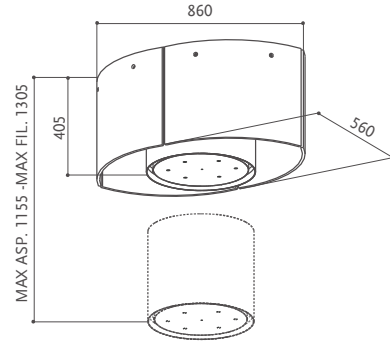

The hood can also be operated by using the controls on a Faber hob

NEST PLUS

NEST PLUS cod. 345.0492.592



HOOD&HOB

FEATURES	PERFORMANCE	ACCESSORIES
Finish • Stainless steel / Glass	Speed 1 2 3 INT	Cod. 112.0158.127
Controls Electronic	Air capacity IEC point 270 340 430 620	FHP8 High Performance Charcoal filter
Lighting Micro LED lights	Pressure 400 460 530 560	Cod. 112.0169.216
Grease filter Cassettes dishwasher safe	Input 120 150 190 270	F-LIGHT ducting kit
Ø of air outlet 150 mm	Noise level 52 58 64 71	Cod. 112.0185.278
Width 860 mm		FLL8 Long Lasting Charcoal filter
Energy class A		



**BRAND
NEW**

Featuring unique circular LED lighting coupled with modern matt finishes.



Grey Matt

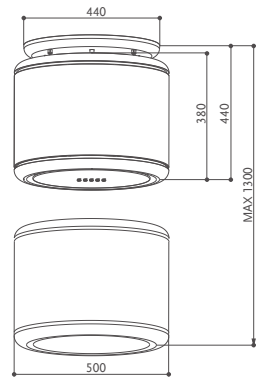

The hood can also be operated by using the controls on a Faber hob

ODETTE PLUS



ODETTE PLUS BK MATT cod. 345.0541.053
ODETTE PLUS GREY MATT cod. 345.0541.054

ODETTE

ODETTE BK MATT cod. 345.0541.009
ODETTE GREY MATT cod. 345.0541.010



(optional)

HOOD&HOB

FEATURES	PERFORMANCE	ACCESSORIES
Finish • Black matt • Grey matt	Speed 1 2 3 INT	Cod. 112.0158.127 FHP8 High Performance Charcoal filter
Controls Touch control	Air capacity IEC point 240 300 430 640	Cod. 112.0185.278 FLL8 Long Lasting Charcoal filter
Lighting Perimetral LED light	Pressure 280 410 510 540	Cod. 112.0542.875 Airline ducting kit
Grease filter Cassettes dishwasher safe	Input 95 125 185 230	
Ø of air outlet 150 mm	Noise level 51 54 58 68	
Width 500 mm		
Energy class A		



Stainless steel



Tibetan silver
Limited Edition



This distinctive periscopic hood is both unique and breathtaking.

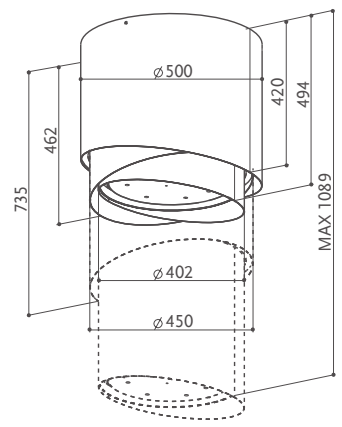

PAREO PLUS

PAREO PLUS cod. 345.0492.593
 PAREO PLUS TIBETAN SILVER cod. 345.0492.594

The hood can also be operated by using the controls on a Faber hob

UP & DOWN

EVO DIFFUSER

PERIMETER ASPIRATION

INTENSIVE SPEED

DELAY 30

HOUR 24

NEW REMOTE CONTROL

MICRO LED

CONNECTION

ENERGY

HOOD&HOB

FEATURES	PERFORMANCE
Finish • Stainless steel • Tibetan silver	Speed 1 2 3 INT
Controls Electronic	Air capacity IEC point 270 340 430 620
Lighting Micro LED lights	Pressure 400 460 530 560
Grease filter Cassettes dishwasher safe	Input 120 150 190 270
Ø of air outlet 150 mm	Noise level 52 58 64 71
Width 500 mm	
Energy class A	

The model is exclusively available as a ducted hood.



A frosted glass chandelier shrouds the powerful up-and-down extractor.

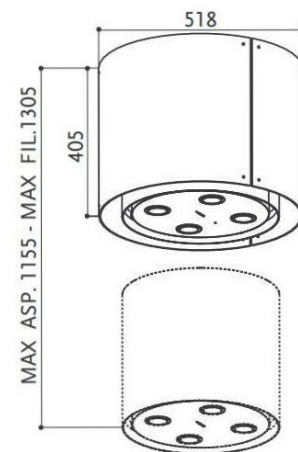

VANILLA PLUS

VANILLA PLUS cod. 345.0492.591



HOOD&HOB

FEATURES	PERFORMANCE	ACCESSORIES
Finish • Stainless steel / Glass	Speed 1 2 3 INT	Cod. 112.0158.127 FHP8 High Performance Charcoal filter
Controls Electronic	Air capacity IEC point 270 340 430 620	Cod. 112.0169.216 F-LIGHT ducting kit
Lighting Micro LED lights	Pressure 400 460 530 560	Cod. 112.0185.278 FLL8 Long Lasting Charcoal filter
Grease filter Cassettes dishwasher safe	Input 120 150 190 270	
Ø of air outlet 150 mm	Noise level 52 58 64 71	
Width 520 mm		
Energy class A		



Simple yet stylish extractor with up-and-down technology.

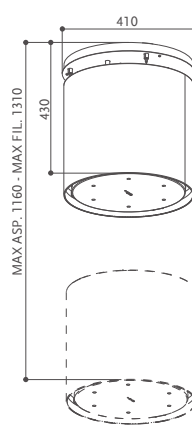

Zoom, ducted version

The hood can also be operated by using the controls on a Faber hob

ZOOM PLUS

ZOOM PLUS cod. 345.0492.568

UP & DOWN	EVO DIFFUSER	PERIMETER ASPIRATION	INTENSIVE SPEED	DELAY 30	HOUR 24	NEW REMOTE CONTROL	MICRO LED	CONNECTION	ENERGY
-----------	--------------	----------------------	-----------------	----------	---------	--------------------	-----------	------------	--------

HOOD&HOB

FEATURES	PERFORMANCE	ACCESSORIES
Finish · Stainless steel	Speed 1 2 3 INT	Cod. 112.0158.127
Controls Electronic	Air capacity IEC point 270 340 430 620	FHP8 High Performance Charcoal filter
Lighting Micro LED lights	Pressure 400 460 530 560	Cod. 112.0169.216 F-LIGHT ducting kit
Grease filter Cassettes dishwasher safe	Input 120 150 190 270	Cod. 112.0185.278 FLL8 Long Lasting Charcoal filter
Ø of air outlet 150 mm	Noise level 52 58 64 71	
Width 400 mm		
Energy class A		

CORINTHIA ISOLA





WH MATT/TS
White matt/Tibetan silver



Stainless steel/Old metal - X/OM



DG MATT/CONCRETE
Dark grey matt/Concrete

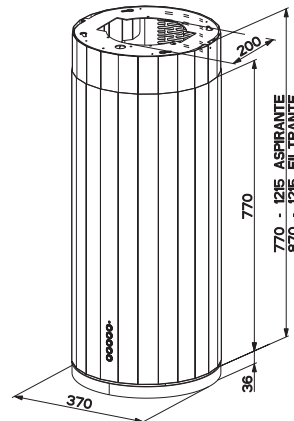

Precious metal effect and industrial styling combined.

CORINTHIA ISOLA

CORINTHIA ISOLA EV8+ WH MATT/TS A37 cod. 110.0456.219
CORINTHIA ISOLA EV8+ DG MATT/CONCRETE A37 cod. 110.0456.220
CORINTHIA ISOLA EV8+ X/OM A37 cod. 110.0456.261

(optional)			HOOD&HOB			

FEATURES	PERFORMANCE	ACCESSORIES
Finish • White matt / Tibetan silver • Dark grey matt / Concrete • Stainless steel / Old metal	Speed 1 2 3 INT Air capacity IEC point 260 365 480 600 Pressure 390 500 510 530 Input 170 215 245 275 Noise level 56 62 68 71	Cod. 112.0157.243 F9 Charcoal filter Cod. 112.0540.043 Remote control Cod. 112.0185.276 FLL9 Charcoal filter Long Lasting
Controls Squarcle touch		
Lighting Micro LED lights		
Grease filter Cassettes dishwasher safe		
Ø of air outlet 150 / 120 mm		
Width 370 mm		
Energy class A		

Stainless steel



Imposing cylindrical extraction.

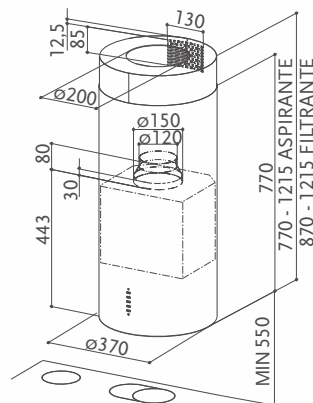

To be installed at a minimum distance from the hob of **55 cm**.

CYLINDRA ISOLA

CYLINDRA ISOLA EV8 X A37 ELN cod. 110.0332.308



(optional)

(optional)

FEATURES	PERFORMANCE	ACCESSORIES
Finish • Stainless steel	Speed 1 2 3 INT	Cod. 112.0157.243
Controls Electronic LED	Air capacity IEC point 300 460 590 650	F9 Charcoal filter Cod. 112.0540.043
Lighting 2 LED lights	Pressure 350 450 480 490	Remote control Cod. 112.0327.007
Grease filter Cassettes dishwasher safe	Input 145 180 230 250	ENERGY Remote blower kit Cod. 112.0157.267
Ø of air outlet 150 / 120 mm	Noise level 56 62 68 71	Upper chimney kit X Cod. 112.0185.276
Width 370 mm		FLL9 Charcoal filter Long Lasting
Energy class C		

Imposing cylindrical extraction, with a modern concrete finish.



White

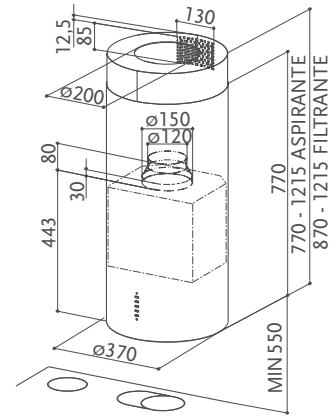

To be installed at a minimum distance from the hob of **55 cm**.

CYLINDRA ISOLA PLUS CONCRETE

CYLINDRA ISOLA PLUS CONCRETE A37 cod. 335.0492.564



FEATURES	PERFORMANCE	ACCESSORIES
Finish • Concrete	Speed 1 2 3 INT	Cod. 112.0157.243
Controls Feel touch	Air capacity IEC point 280 420 580 680	F9 Charcoal filter Cod. 112.0540.043
Lighting Micro LED lights	Pressure 430 500 530 545	Remote control Cod. 112.0327.007
Grease filter Cassettes dishwasher safe	Input 190 230 255 270	ENERGY Remote blower kit Cod. 112.0185.276
Ø of air outlet 150 / 120 mm	Noise level 56 62 68 71	FLL9 Charcoal filter Long Lasting
Width 370 mm		
Energy class A		

T-LIGHT ISOLA



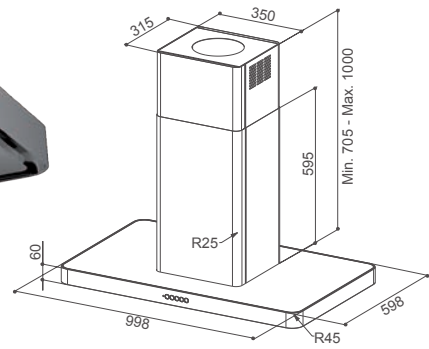

T-LIGHT ISOLA

T-LIGHT ISOLA EV8+ X A100 cod. 110.0456.264
 T-LIGHT ISOLA EV8+ WH MATT A100 cod. 110.0456.265

The hood can also be operated by using the controls on a Faber hob

EVO DIFFUSER

PERIMETER ASPIRATION

INTENSIVE SPEED

NEW REMOTE CONTROL

LED LIGHT

CONNECTION

ENERGY A

(optional) HOOD&HOB

FEATURES	PERFORMANCE	ACCESSORIES
Finish • Stainless steel • White matt	Speed 1 2 3 INT	Cod. 112.0157.243
Controls Squarcle touch	Air capacity IEC point 290 420 580 690	F9 Charcoal filter Cod. 112.0540.043
Lighting Perimeter LED light	Pressure 410 470 520 530	Remote control Cod. 112.0185.276
Grease filter Cassettes dishwasher safe	Input 190 230 255 270	FLL9 Charcoal filter Long Lasting
Ø of air outlet 150 / 120 mm	Noise level 50 58 65 68	
Width 1000 mm		
Energy class A		

**Faber's
timeless
T-Shaped
chimney hood,
simple and
effective.**

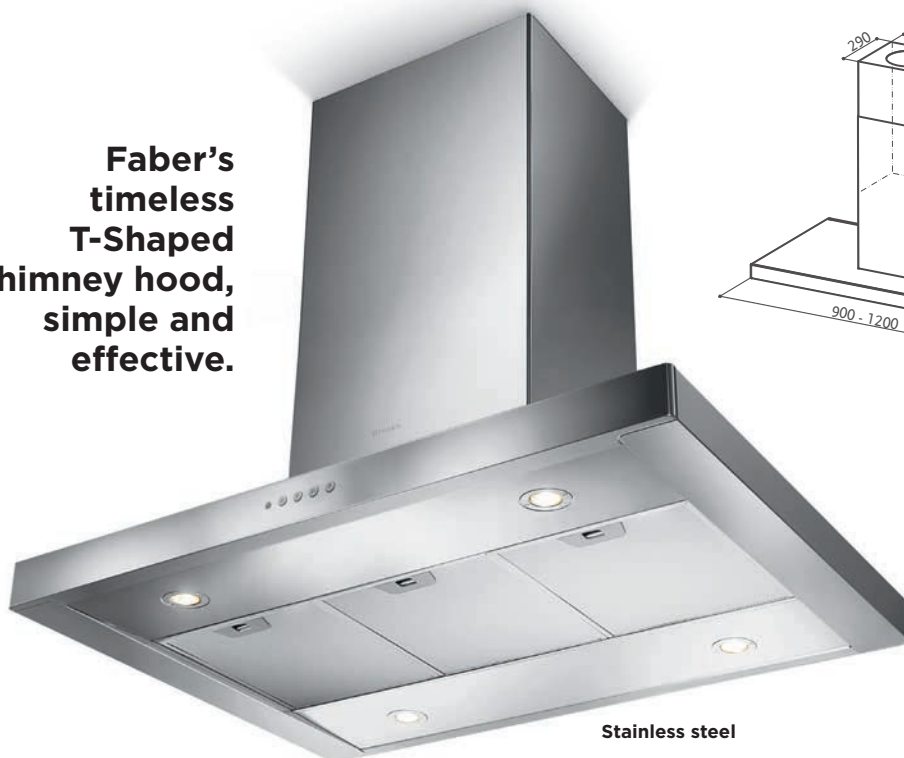

Stainless steel

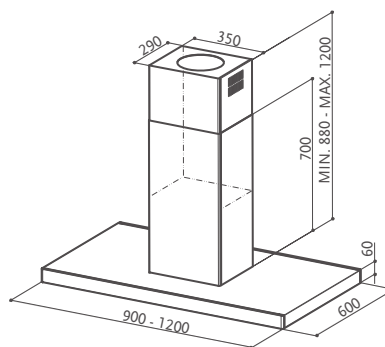

STILO ISOLA/SP

STILO ISOLA/SP EV8 X A90 cod. 110.0255.544

STILO ISOLA/SP EV8 X A120 cod. 1110.0255.545



(optional)

FEATURES	PERFORMANCE	ACCESSORIES
Finish • Stainless steel	Speed 1 2 3 INT	Cod. 112.0067.944 F3 Charcoal filter
Controls Electronic	Air capacity IEC point 300 460 620 700	Cod. 112.0327.007 ENERGY Remote blower kit
Lighting 4 LED lights	Pressure 330 430 490 500	Cod. 112.0185.276 FLL9 Charcoal filter Long Lasting
Grease filter Cassettes dishwasher safe	Input 145 180 230 250	
Ø of air outlet 150 / 120 mm	Noise level 52 62 69 71	
Width 900 / 1200 mm		
Energy class B		

CEILING HOODS

For the ultimate in discreet extraction, a Faber ceiling hood illuminates the cooking area whilst drawing your steam towards the ceiling.

Faber's best selling ceiling hood; easy to install, powerful and great value.

The hood can also be operated by using the controls on a Faber hob

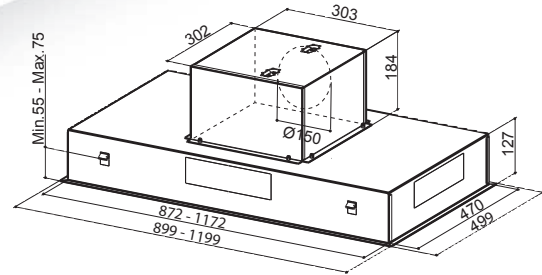

Air outlet adjustable in 4 positions

HEAVEN 2.0

HEAVEN 2.0 EV8+ X 90 cod. 110.0315.792
HEAVEN 2.0 EV8+ X 120 cod. 110.0315.794



FEATURES	PERFORMANCE	ACCESSORIES
Finish • Stainless steel	Speed 1 2 3 INT	Cod. 112.0327.007
Controls Electronic LED	Air capacity IEC point 290 400 560 700	ENERGY Remote blower kit
Lighting 4 LED lights	Pressure 430 490 530 560	Cod. 112.0158.127
Grease filter Cassettes dishwasher safe	Input 190 230 255 270	FHP8 High Performance Charcoal filter
Ø of air outlet 150 / 120 mm	Noise level 53 62 70 72	Cod. 112.0185.278
Width 900 mm / 1200 mm		FLL8 Long Lasting Charcoal filter
Energy class A		Cod. 112.0376.219
		Flat Air Duct System Heaven

HEAVEN COMPACT



Specially designed
to fit in-between
ceiling joists.

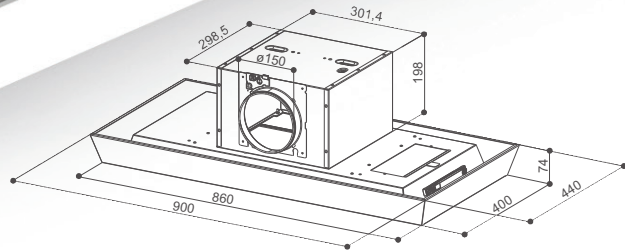

Air outlet adjustable in 4 positions

HEAVEN COMPACT

HEAVEN COMPACT EV8 X A90 cod. 350.0504.298



The hood can also be operated by using the controls on a Faber hob

HOOD&HOB

FEATURES	PERFORMANCE	ACCESSORIES
Finish • Stainless steel / White glass	Speed 1 2 3 INT	Cod. 112.0327.007
Controls Electronic LED	Air capacity IEC point 300 460 580 640	ENERGY Remote blower kit
Lighting 2 LED lights	Pressure 360 440 500 510	Cod. 112.0185.278
Grease filter Cassettes dishwasher safe	Input 145 180 230 250	FLL8 Long Lasting Charcoal filter
Ø of air outlet 150 / 120 mm	Noise level 53 63 68 70	Cod. 112.0158.127
Width 900 mm		FHP8 High Performance Charcoal filter
Energy class C		

A timeless glass ceiling hood with a host of installation options.

The hood can also be operated by using the controls on a Faber hob



Air outlet adjustable in 4 positions

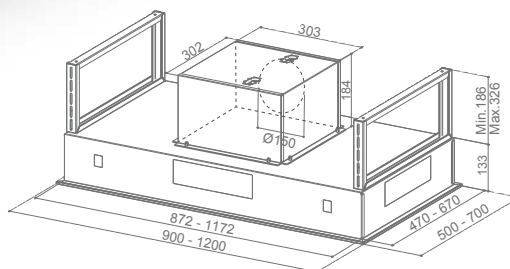

HEAVEN GLASS 2.0

HEAVEN GLASS 2.0 EV8+ WH A90 cod. 110.0315.503

HEAVEN GLASS 2.0 EV8+ WH A120 cod. 110.0374.230

										
(optional)										HOOD&HOB

FEATURES	PERFORMANCE	ACCESSORIES
Finish · White glass	Speed 1 2 3 INT	Cod. 112.0327.007
Controls Electronic LED	Air capacity IEC point 290 400 560 700	ENERGY Remote blower kit
Lighting 2 LED lights	Pressure 430 490 530 560	Cod. 112.0158.127
Grease filter Cassettes dishwasher safe	Input 190 230 255 270	FHP8 High Performance Charcoal filter
Ø of air outlet 150 / 120 mm	Noise level 53 62 70 72	Cod. 112.0185.278
Width 900 mm / 1200 mm		FLL8 Long Lasting Charcoal filter
Energy class A		Cod. 112.0376.219
		Flat Air Duct System Heaven



Heaven Glass 2.0 Slim

Designed for tighter spaces above the ceiling.



Heaven 2.0 Slim

The hood is linked to the hob due to its controls integrated in the Faber hobs.

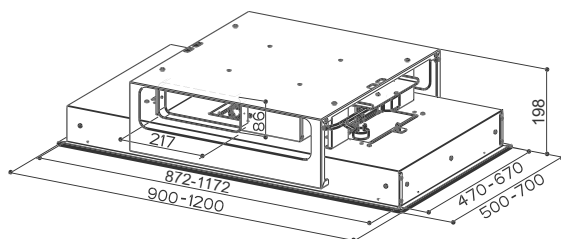

Heaven Glass 2.0 Slim

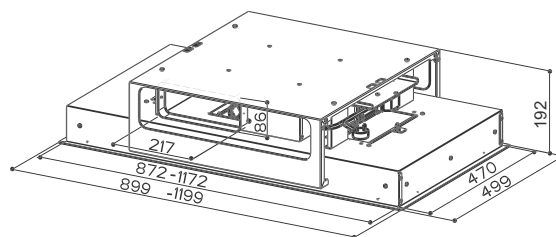

Heaven 2.0 Slim

HEAVEN GLASS 2.0 SLIM HEAVEN 2.0 SLIM

HEAVEN GLASS 2.0 WH SLIM A90 cod. 110.0428.440

HEAVEN GLASS 2.0 WH SLIM A120 cod. 110.0428.451

HEAVEN GLASS 2.0 X SLIM A90 cod. 110.0428.452

HEAVEN GLASS 2.0 X SLIM A120 cod. 110.0428.453



HOOD&HOB

FEATURES	PERFORMANCE	ACCESSORIES
Finish • Stainless steel • White glass	Speed 1 2 3 INT Air capacity IEC point 480 550 620 700	Cod. 112.0471.608 FLL18-90 Charcoal filter 90cm
Controls Electronic LED	Pressure 310 410 520 690 Input 60 85 110 145	Cod. 112.0471.609 FLL18-120 Charcoal filter 120cm
Lighting 2 LED lights	Noise level 63 66 70 72	Cod. 112.0459.429 Round to Rectangular Adapter 200x90mm
Grease filter Cassettes dishwasher safe		
Ø of air outlet 220 x 90 mm		
Width 900 mm		
Energy class A+		

The latest Heaven ceiling hood design in White glass or Stainless steel.

Air outlet adjustable in 4 positions



Heaven Lite



Heaven Lite Glass

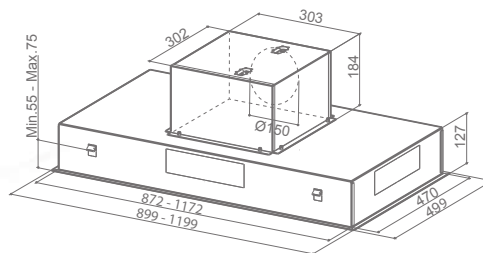

Heaven Lite

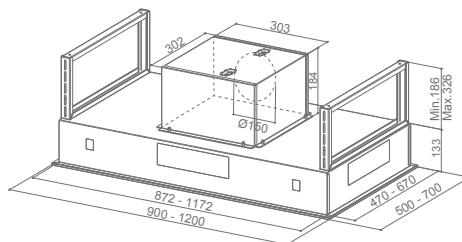

Heaven Lite Glass

The hood can also be operated by using the controls on a Faber hob

HEAVEN LITE HEAVEN LITE GLASS

HEAVEN LITE EV8+ X A90 cod. 350.0529.507
HEAVEN LITE EV8+ X A120 cod. 350.0529.508

HEAVEN LITE GLASS EV8+ WH A90 cod. 350.0529.509
HEAVEN LITE GLASS EV8+ WH A120 cod. 350.0529.510



HOOD&HOB

FEATURES	PERFORMANCE	ACCESSORIES
Finish • White glass • Stainless steel	Speed 1 2 3 INT Air capacity IEC point 290 400 560 700 Pressure 430 490 530 560 Input 190 230 255 270 Noise level 53 62 70 72	Cod. 112.0327.007 ENERGY Remote blower kit Cod. 112.0185.278 FLLP8 Long Lasting Charcoal filter Cod. 112.0376.219 Flat Air Duct System Heaven Cod. 112.0158.127 FHP8 High Performance Charcoal filter
Controls Electronic LED		
Lighting LED lights		
Grease filter Cassettes dishwasher safe		
Ø of air outlet 150 mm		
Width 900 / 1200 mm		
Energy class A		



A contemporary design ceiling hood with a compact motor design.

White Matt

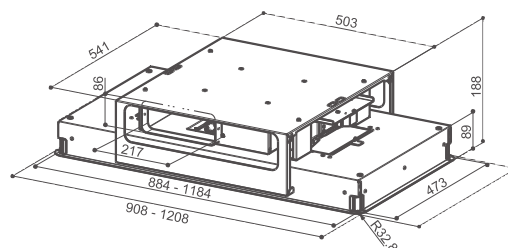
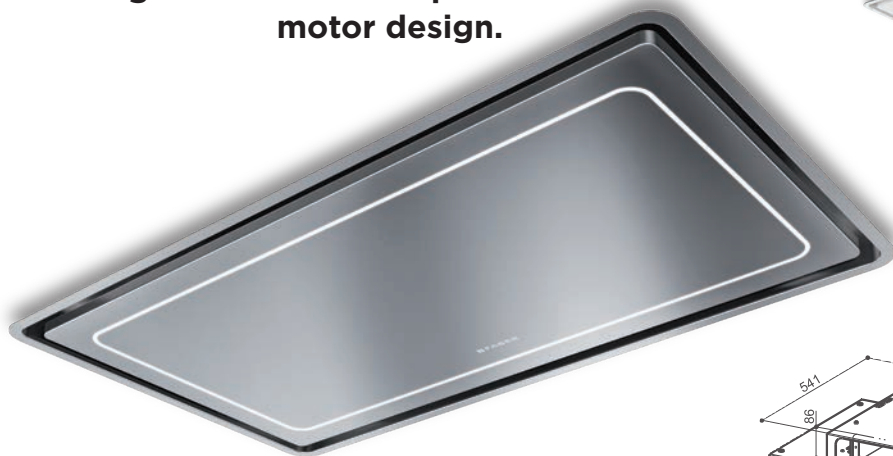

The hood can also be operated by using the controls on a Faber hob

HIGH-LIGHT

HIGH-LIGHT RAD BRS X A91 cod. 110.0456.185
HIGH-LIGHT RAD BRS X A121 cod. 110.0456.205

HIGH-LIGHT RAD BRS WH MATT A91 cod. 110.0456.206
HIGH-LIGHT RAD BRS WH MATT A121 cod. 110.0456.207



HOOD&HOB

FEATURES	PERFORMANCE	ACCESSORIES
Finish • Stainless steel • White matt	Speed 1 2 3 INT	Cod. 112.0471.608 FLL18-90 Charcoal filter 90cm
Controls Electronic LED	Air capacity IEC point 415 490 550 710	Cod. 112.0471.609 F18-120 Charcoal filter
Lighting Perimeter LED light	Pressure 320 410 530 700	Cod. 112.0459.429 Round to Rectangular Adapter 220x90mm
Grease filter Cassettes dishwasher safe	Input 55 85 110 145	
Ø of air outlet 220 x 90 mm	Noise level 63 65 68 71	
Width 910 / 1210 mm		
Energy class A+		

The very first ceiling hood to move up and down from the ceiling.

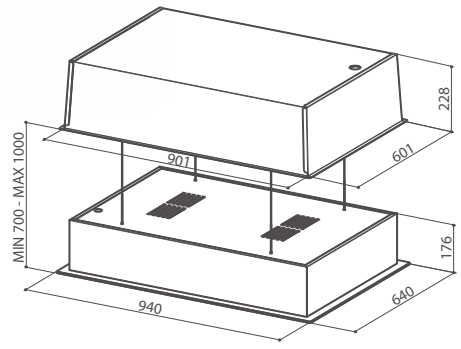
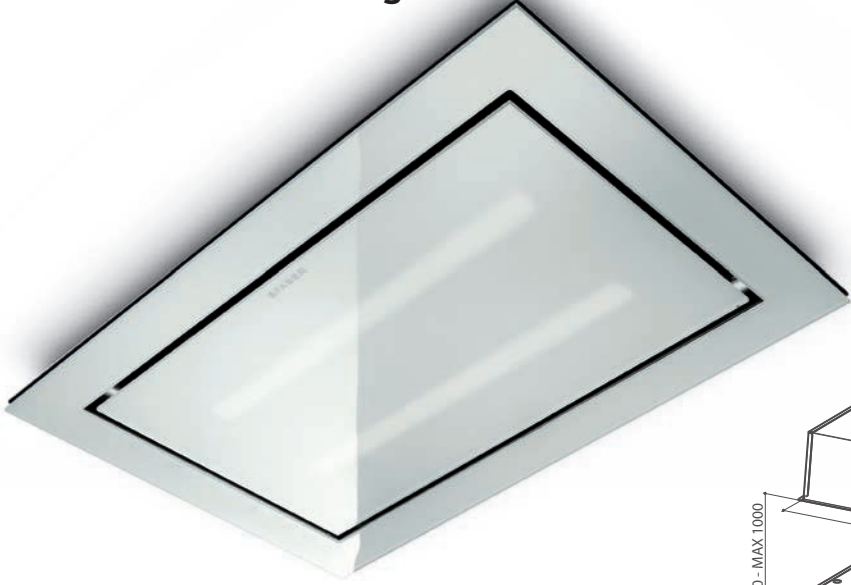

SKYLIFT

SKYLIFT cod. 110.0324.939

The hood can also be operated by using the controls on a Faber hob

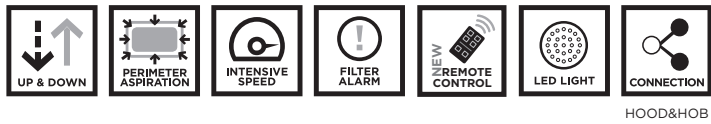

FEATURES	PERFORMANCE	ACCESSORIES
Finish • White glass	Speed 1 2 3 4 INT	Cod. 112.0329.927
Controls Electronic	Air capacity IEC point 110 195 260 313 430	FHP13 Skylift High Performance Charcoal filter
Lighting 2 LED lights	Pressure - - - - -	*Charcoal filters included
Grease filter Cassettes dishwasher safe	Input 30 45 55 70 100	
Ø of air outlet -	Noise level 48 53 58 62 69	
Width 900 mm		
Energy class - *		

* Data not declared, as the model is exclusively available as a recirculating hood.

SKYPAD 2.0



Fixed directly to the ceiling surface; no cut-out is needed.

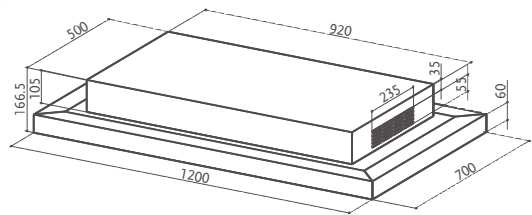

The hood can also be operated by using the controls on a Faber hob

SKYPAD 2.0

SKYPAD 2.0 X/WH F120 cod. 110.0479.462



HOOD&HOB

FEATURES	PERFORMANCE	ACCESSORIES
Finish • Stainless steel / White glass	Speed 1 2 3 INT	Cod. 112.0329.928
Controls Electronic LED	Air capacity IEC point 440 600 780 850	FHP14 Skypad High Performance Charcoal filter
Lighting 2 LED lights	Pressure - - - -	*Charcoal filters included.
Grease filter Cassettes dishwasher safe	Input 60 90 140 180	
Ø of air outlet -	Noise level 57 64 70 72	
Width 1200 mm		
Energy class -*		
Motors 2		

* Data not declared, as the model is exclusively available as a recirculating hood.

DOWNDRAFT HOODS AND VENTING HOBS

With the extraction unit hidden cleverly beneath the hob, these extractors offer the ultimate in discrete extraction whilst taking up minimal space in the kitchen cabinet.

This hood rises up out of the work top providing totally discreet extraction.



Stainless steel / White glass

Stainless steel / Black Glass

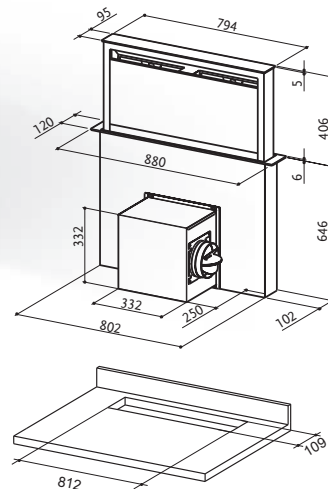

Air outlet adjustable in 4 positions, front or rear side

FABULA PLUS

FABULA PLUS EV8+ BK A90 cod. 340.0492.566
 FABULA PLUS EV8+ WH A90 cod. 340.0492.567

(optional)				(optional)					

FEATURES	PERFORMANCE	ACCESSORIES
Finish • Stainless steel / Black glass • Stainless steel / White glass	Speed 1 2 3 4 INT	Cod. 112.0261.258
Controls EVO Touch control	Air capacity IEC point 160 290 350 439 700	F12 Fabula Charcoal filter Cod. 112.0540.043
Lighting LED lights	Pressure 100 390 460 540 560	Remote control Cod. 112.0327.008
Grease filter Cassettes dishwasher safe	Input 55 120 155 210 270	Remote blower kit Fabula Cod. 112.0470.541*
Ø of air outlet 150 / 120	Noise level 40 53 54 60 70	Rectangular Duct Recirculating Kit
Width 900 mm		
Energy class A		*To be purchased in addition or as an alternative to the Charcoal filter.



GALILEO





SIMPLY GENIUS

The Galileo hood, named after a true Italian genius, is a jewel of technology in energy efficiency class A+++, and the top of Faber's induction range. Invisible but extremely functional, Galileo is a perfect combination of hood and hob in a single, worktop-height package.



The hood and hob form a superbly efficient duo, characterised by attention to detail and amazing performance. Touch slider controls are complemented by maximum power, total safety and silence.

Double boost and 5 suction speeds.



CAST IRON GRID FLUSH FIT



Galileo stands out for its waterproof motor technology, which guarantees normal functioning and complete safety even if large quantities of liquid are spilled on the hob.



The motor's compact design also means that Galileo is the only product in its class that leaves enough free space inside the cabinet for a utensil drawer to be fitted immediately beneath.



GALILEO



AUTOMATIC FUNCTION
 The hood will turn on at the most suitable speed automatically, adapting the extraction capacity to the maximum cooking level. To deactivate this function simply press the key A, later it can be started up again by pressing the same control and the LED "A" will light up.

BRAND NEW



The product is also equipped for installation in 60 cm deep worktops.



Rear ducting version installation



Lateral ducting version installation



Front recirculating version installation

NOT FLUSH FIT INSTALLATION

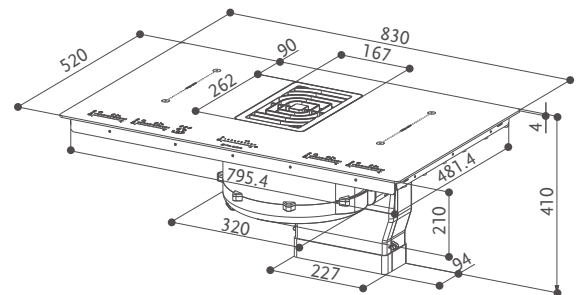
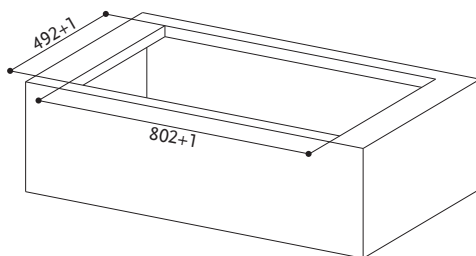

FLUSH FIT INSTALLATION

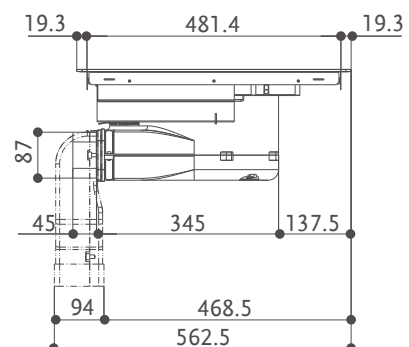
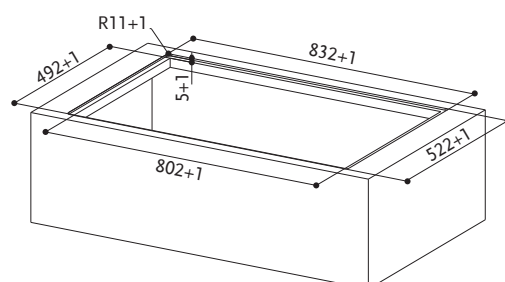

WALL HOODS

Using only the finest materials, our wall hoods have been designed to be an attractive addition to your kitchen. They conceal a powerful motor and refined extraction systems to guarantee clean air.



D. FABER



Old Brass - OB



Old Copper - OC



Cast Iron - CI



Dark Grey Matt - DG MATT



Old Metal - OM



Country Grey Matt - CG MATT



**Retro design
featuring stunning
metallic finishes for
an industrial look.**

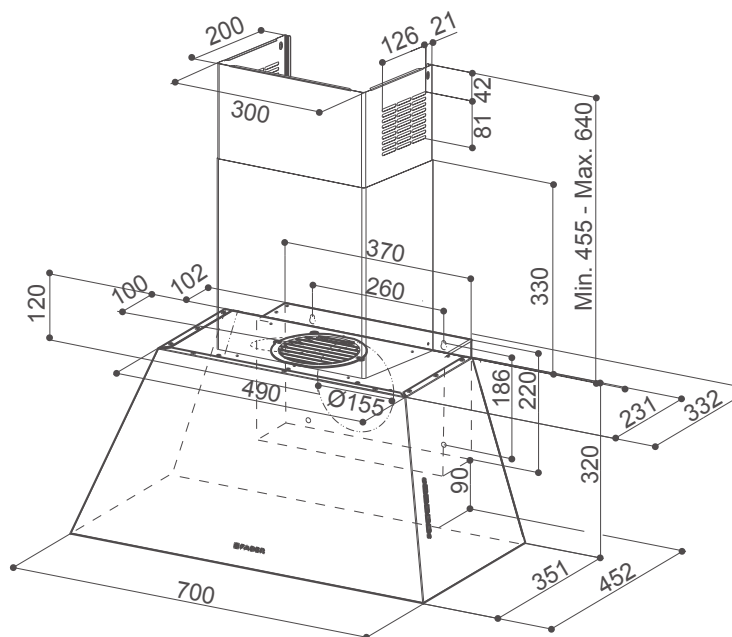

Rear Air Outlet Kit (optional)

The hood can also be operated by using the controls on a Faber hob

CHLOÈ

CHLOÈ EV8+ OM A70 cod. 110.0456.129
CHLOÈ EV8+ OC A70 cod. 110.0456.174
CHLOÈ EV8+ CI A70 cod. 110.0456.175

CHLOÈ EV8+ OB A70 cod. 110.0456.177
CHLOÈ EV8+ DG MATT A70 cod. 110.0458.989
CHLOÈ EV8+ CG MATT A70 cod. 110.0459.033



FEATURES	PERFORMANCE	ACCESSORIES	
Finish	Speed	1 2 3 INT	Cod. 112.0540.043 Cod. 112.0490.250
• Old metal • Old copper • Cast iron • Old brass • Dark grey matt • Country grey matt	Air capacity IEC point	300 420 590 700	Remote control Rear air outlet kit OC
Controls	Pressure	440 500 540 550	Cod. 112.0327.007
Electronic LED	Input	190 230 255 270	ENERGY Remote blower kit Cod. 112.0490.261
Lighting	Noise level	51 59 66 69	Rear air outlet kit CI
LED light			Cod. 112.0158.127
Grease filter			FHP8 Charcoal filter High Performance Cod. 112.0490.262
Cassettes dishwasher safe			Cod. 112.0185.278
Ø of air outlet			FLL8 Charcoal filter Long Lasting Cod. 112.0490.263
150 /120 mm			Rear air outlet kit DG MATT
Width			Cod. 112.0490.249
700 mm			Rear air outlet kit OM Cod. 112.0490.264
Energy class			Rear air outlet kit CG MATT
A			

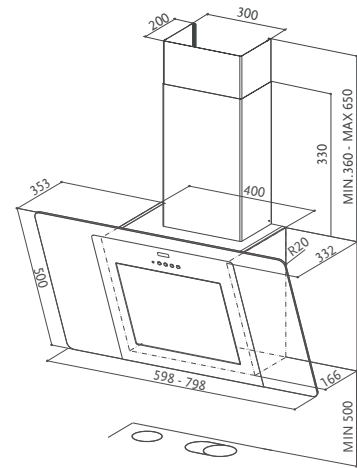

To be installed at a minimum distance from the hob of **50 cm**.



One of Faber's best selling wall models; great value, great style

CITY

CITY EG6 BK/X A80 cod. 110.0322.124
CITY EG6 W/X A80 cod. 110.0322.126
CITY EG6 X A80 cod. 110.0322.125

CITY EG6 BK/X A60 cod. 110.0322.128
CITY EG6 W/X A60 cod. 110.0322.129



The City is ^(optional) not recommended for use over an induction hob

FEATURES	PERFORMANCES	ACCESSORIES
Finish · Stainless steel / Black glass · Stainless steel / White glass · Stainless steel	Speed 1 2 3 INT	Cod. 112.0327.007 ENERGY Remote blower kit
Controls Electronic	Air capacity IEC point 270 390 470 520	Cod. 112.0327.632 Recycling Version Kit S-Steel
Lighting LED light	Pressure 200 260 290 310	Cod. 133.0195.967 Chimney Recycling Kit S-Steel
Grease filter Cassettes dishwasher safe	Input 90 105 125 140	Cod. 133.0046.956 Internal Chimney Recirculating Kit
Ø of air outlet 150 / 120 mm	Noise level 57 63 68 69	Cod. 112.0158.127 FHP8 Charcoal filter High Performance
Width 600 / 800 mm		Cod. 112.0185.278 FLL8 Charcoal filter Long Lasting
Energy class C		



A timeless
glass wall hood
with powerful
extraction .



Black

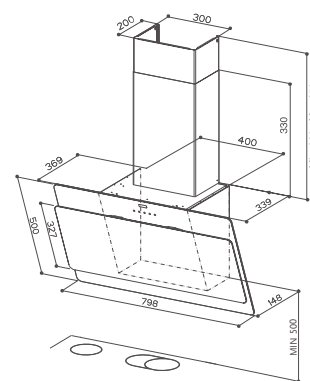
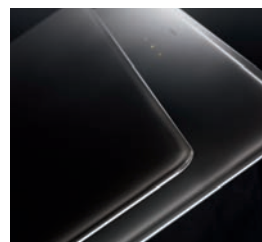

To be installed at a minimum
distance from the hob of **50 cm**.

COCKTAIL

COCKTAIL EV8 BK A80 COD. 110.0252.427

COCKTAIL EV8 WH A80 COD. 110.0252.428



FEATURES	PERFORMANCES	ACCESSORIES
Finish <ul style="list-style-type: none"> • White glass • Black glass 	Speed 1 2 3 INT Air capacity IEC point 310 480 630 720 Pressure 350 450 480 520 Input 145 180 230 250 Noise level 52 62 67 70	Cod. 112.0158.127 FHP8 Charcoal filter High Performance Cod. 112.0185.278 FLL8 Charcoal filter Long Lasting Cod. 133.0046.956 Internal Chimney Recirculating Kit Cod. 112.0252.439 Recycling Version Kit WH Cod. 112.0252.442 Recycling Version Kit BK Cod. 133.0301.599 Upper Chimney Recirculating Kit WH Cod. 133.0272.534 Upper Chimney Recirculating Kit BK
Controls Touch control		
Lighting 2 LED lights		
Grease filter Cassettes dishwasher safe		
Ø of air outlet 150 / 120 mm		
Width 800 mm		
Energy class C		



The petite version
of a classic Faber
hood, designed for
the smaller kitchen.

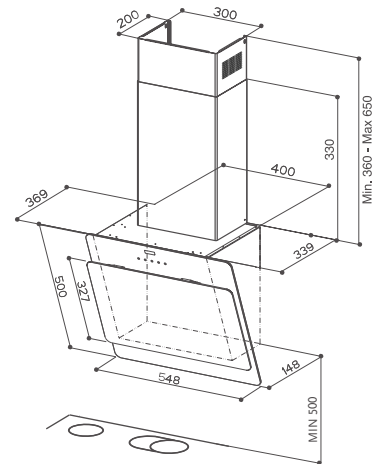

To be installed at a minimum
distance from the hob of **50 cm**.

COCKTAIL XS

COCKTAIL XS EV8 BK A55 cod. 110.0256.810
COCKTAIL XS EV8 WH A55 cod. 110.0256.821



FEATURES	PERFORMANCES	ACCESSORIES
Finish • White glass • Black glass	Speed 1 2 3 INT	Cod. 112.0158.127 FHP8 Charcoal filter High Performance Cod. 112.0252.442 Recycling Version Kit BK
Controls Touch control	Air capacity IEC point 285 415 500 535	Cod. 133.0301.599 Upper Chimney Recirculating Kit WH
Lighting 2 LED lights	Pressure 190 265 280 290	Cod. 133.0046.956 Internal Chimney Recirculating Kit Cod. 133.0272.534 Upper Chimney Recirculating Kit BK
Grease filter Cassettes dishwasher safe	Input 90 105 125 140	Cod. 112.0252.439 Recycling Version Kit WH
Ø of air outlet 150 / 120 mm	Noise level 56 62 66 68	
Width 550 mm		
Energy class C		

Top or rear ducting makes this stylish hood incredibly versatile



Black Glass

White glass

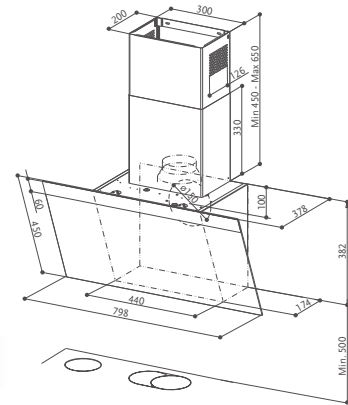

To be installed at a minimum distance from the hob of **50 cm**.

DAISY B

DAISY B EG6 BK A55 cod. 330.0529.064
DAISY B EG6 BK A80 cod. 330.0529.063

DAISY B EG6 WH A55 cod. 330.0529.065
DAISY B EG6 WH A80 cod. 330.0529.061



(optional)

FEATURES	PERFORMANCES	ACCESSORIES
Finish • Black glass • White glass	Speed 1 2 3 INT	Cod. 112.0327.007 ENERGY Remote blower kit
Controls Touch control	Air capacity IEC point 290 430 510 550	Cod. 112.0327.632 Recycling version kit X
Lighting 2 LED lights	Pressure 215 280 300 320	Cod. 112.0158.127 FHP8 Charcoal filter High Performance
Grease filter Cassettes dishwasher safe	Input 90 105 125 140	Cod. 112.0185.278 FLL8 Charcoal filter Long Lasting
Ø of air outlet 150 / 120 mm	Noise level 56 63 68 70	Cod. 133.0046.956 Internal Chimney Recirculating Kit
Width 550 / 800 mm		
Energy class C		

*This model can be ducted from the top or rear.

GLAM-FIT



**BRAND
NEW**

**This truly vertical
wall hood gives
you more space
above the hob.**



Glam-Fit Black Glass



Glam-Fit White glass



550 mm



550 mm



A VERTICAL HOOD WITH THE LATEST NAUTILUS TECHNOLOGY.

Glamorous by name and nature, the Glam-Fit hood is characterised by a minimal, contemporary style that radiates elegance in every detail.

Its clean, essential lines, complemented by a glass surface and an elegant clear surround, add refinement to any kitchen and conceal Faber's exclusive Nautilus technology.

The first ever completely flat, vertical glass hood, Glam-Fit also features an ultra-thin body of only 15 cm. Impressive performance and economic consumption place it in energy efficiency class A.

Glam-Fit comes in two finishes, black and white, both equally striking and typically Faber. Glam-Fit is also available in a "small" 55 cm version.

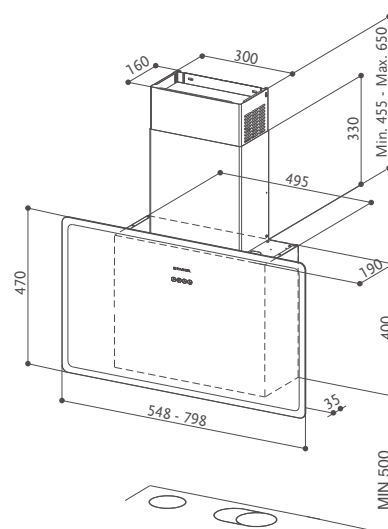

To be installed at a minimum distance from the hob of **50 cm**.

GLAM-FIT

GLAM FIT 80 BK FABER cod. 330.0528.269
GLAM FIT 55 BK FABER cod. 330.0528.270

GLAM FIT 55 WH FABER cod. 330.0528.301
GLAM FIT 80 WH FABER cod. 330.0528.302



FEATURES	PERFORMANCE	ACCESSORIES
Finish • Black glass • White glass	Speed 1 2 3 INT	Cod. 112.0540.783 F22 Charcoal filter
Controls Touch control	Air capacity IEC point 190 250 400 570	
Lighting 2 LED lights	Pressure 300 450 540 650	
Grease filter Cassettes dishwasher safe	Input 100 115 120 125	
Ø of air outlet 150 / 120 mm	Noise level 52 58 67 73	
Width 550 / 800 mm		
Energy class A		

The Grexia hood is made from a porcelain ceramic that emulates the look of natural marble.

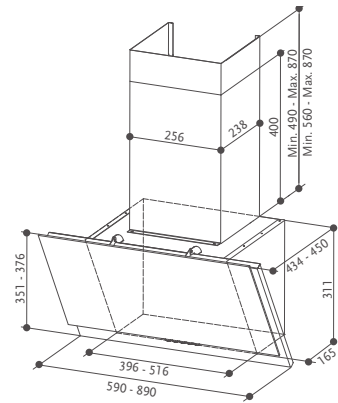

GRÈXIA

GRÈXIA GRES DG/BK A60 cod. 330.0543.464
GRÈXIA GRES DG/BK A90 cod. 330.0543.465

GRÈXIA GRES LG/X A60 cod. 330.0543.467
GRÈXIA GRES LG/X A90 cod. 330.0543.468



(optional)

FEATURES	PERFORMANCE	ACCESSORIES
Finish • Dark grey stoneware / Black • Light grey stoneware /Stainless steel	Speed 1 2 3 INT Air capacity IEC point 300 480 620 690 Pressure 340 430 470 480 Input 145 180 230 250 Noise level 53 64 69 72	Cod. 112.0158.127 FHP8 Charcoal filter High Performance Cod. 112.0185.278 FLL8 Charcoal filter Long Lasting Cod. 112.0540.043 Remote control
Controls Sqaurple touch		
Lighting 2 LED lights		
Grease filter Cassettes dishwasher safe		
Ø of air outlet 150 / 120 mm		
Width 600 / 900 mm		
Energy class C		

**Beautiful porcelain
ceramic finish gives
a classic marble
effect.**



600 mm



900 mm



JOLIE



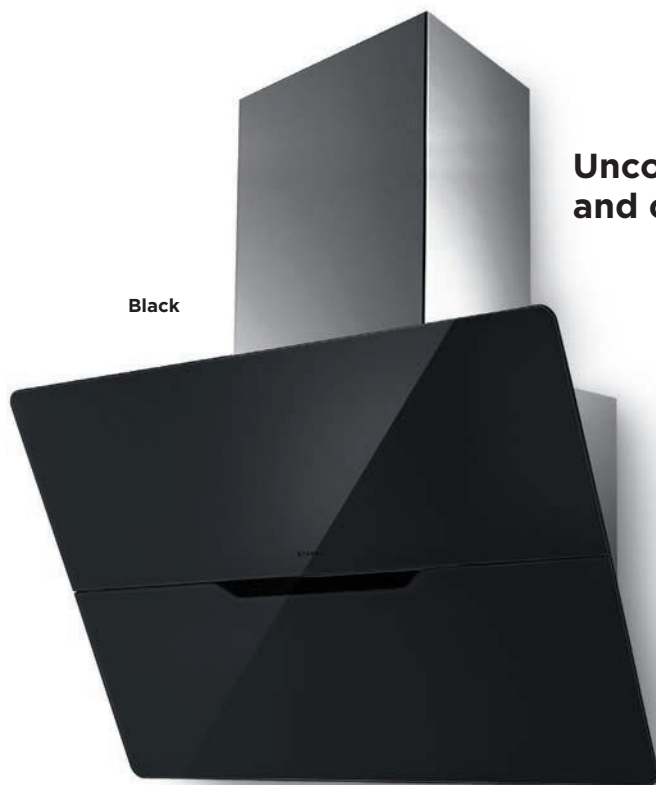

Black

Uncomplicated
and classic.



White

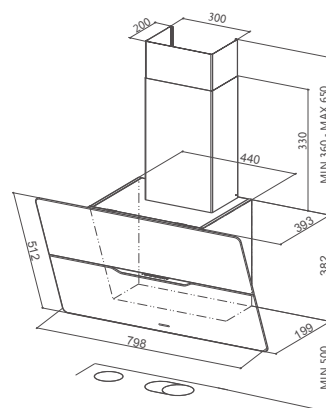

To be installed at a minimum
distance from the hob of **50 cm**.

JOLIE

JOLIE WH A80 cod. 110.0324.936

JOLIE BK A80 cod. 110.0324.937



(optional)

FEATURES	PERFORMANCE	ACCESSORIES
Finish <hr/> <ul style="list-style-type: none"> • White glass • Black glass 	Speed <hr/> 1 2 3 INT	Cod. 112.0327.007 <hr/> ENERGY Remote blower kit
Controls <hr/> Electronic backlight	Air capacity IEC point <hr/> 280 400 480 520	Cod. 112.0327.632 <hr/> Recycling version kit X
Lighting <hr/> 2 LED lights	Pressure <hr/> 190 265 280 290	Cod. 112.0158.127 <hr/> FHP8 Charcoal filter High Performance
Grease filter <hr/> Cassettes dishwasher safe	Input <hr/> 90 105 125 140	Cod. 112.0185.278 <hr/> FLL8 Charcoal filter Long Lasting
Ø of air outlet <hr/> 150 / 120 mm	Noise level <hr/> 57 63 68 69	Cod. 133.0195.967 <hr/> Upper Chimney Recirculating Kit X
Width <hr/> 800 mm		Cod. 133.0046.956 <hr/> Internal Chimney Recirculating Kit
Energy class <hr/> C		

Limited Edition
Concrete



White



Black



Matt White



A timeless
cubic wall
hood.

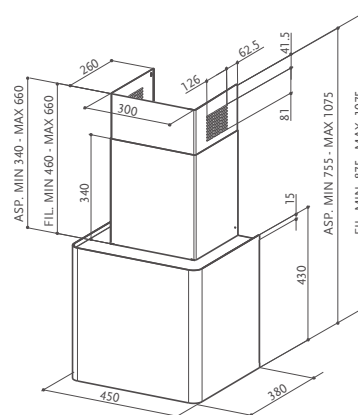

LITHOS

LITHOS EG6 LED BK A45 cod. 335.0533.563

LITHOS EG6 LED WH MATT A45 cod. 335.0533.564

LITHOS EG6 LED WH A45 cod. 335.0533.565

LITHOS CONCRETE cod. 110.0393.916



FEATURES	PERFORMANCE	ACCESSORIES
Finish <ul style="list-style-type: none"> • Black matt • White matt • White • Concrete 	Speed 1 2 3 INT	Cod. 112.0158.127
Controls Electronic	Air capacity IEC point 285 440 535 585	FHP8 Charcoal filter High Performance
Lighting 2 LED lights	Pressure 200 280 300 320	Cod. 112.0185.278
Grease filter Cassettes dishwasher safe	Input 90 105 125 140	FLL8 Charcoal filter Long Lasting
Ø of air outlet 150 / 120 mm	Noise level 54 62 67 69	
Width 450 mm		
Energy class C		

ONYX-T



**BRAND
NEW**

**A truly
attractive
T shape that
is ultra quiet
and eco
friendly.**



Stainless steel

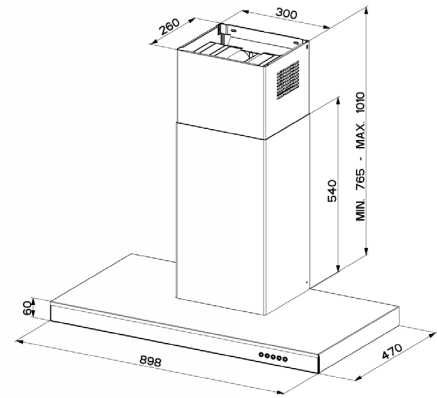

The hood can also be operated
by using the controls on a
Faber hob

ONYX-T

ONYX-T X/V A90 cod. 325.0541.070

SIL & STILL TECHNOLOGY

The Onyx-T uses Faber SIL & STILL noise reducing technology to significantly reduce the noise output during use.

ECO FUNCTION

The ECO function silently refreshes the air using minimal energy.

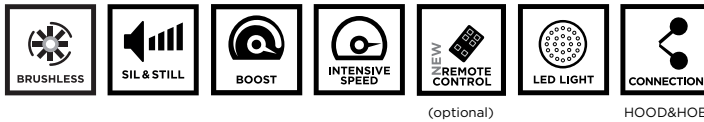

FEATURES	PERFORMANCES	ACCESSORIES
Finish • Stainless steel / Black Glass	Speed 1 2 3 INT BOOST	Cod. 112.0157.243 Charcoal filter
Controls Squarcle touch	Air capacity IEC point 240 300 380 550 750	Cod. 112.0540.043 Remote control
Lighting LED light	Pressure 360 400 450 460 500	Cod. 112.0185.276 FLL9 Charcoal filter Long Lasting
Grease filter Stainless steel cassettes dishwasher safe	Input 55 60 70 100 170	
Ø of air outlet 150 mm	Noise level 45 50 52 63 68	
Width 900 mm		
Energy class A++		

ARIES TECHNOLOGY.

The natural shape of power and efficiency.

FABER'S NEW VERTICAL HOODS FEATURE AN AMAZING FLAT DESIGN.

Now Faber's VERTICAL hoods are becoming even more special, with a thickness of only 15 cm that gives them an ultra-thin, ultra-flat and even more modern look. It's the merit of Faber's new ARIES technology, which concentrates maximum extraction power and energy efficiency into a minimum of space.



UNRIVALLED ENERGY EFFICIENCY: CLASS A+.

ARIES technology harnesses the power of 2 brushless motors to achieve extraction of over 700 m³/h. It's quieter too, producing 9 dB(A) less noise than an equivalent single motor system. ARIES' superior performance in energy saving and silence earns a class A+ energy efficiency rating for Faber's VERTICAL hoods.

ENERGY SHAPED BY NATURE.

ARIES technology takes its name from the shape of the motor which looks a bit like the head of a ram. Power inspired by nature, greater respect for the environment and better, more effective extraction.

**BRAND
NEW**

**Designed by the renowned
Carlo Colombo; a piece of
art in your kitchen.**

The Pyana hood is the result of continuing collaboration between Faber and the internationally famous designer Carlo Colombo. Pyana features a precious, glossfinish body with gently rounded corners and an internal glass panel with an exclusive opening system. Customers can choose between two advanced motor technologies: Nautilus or the new Aries, both guaranteed to deliver superb efficiency with minimum consumption.

**Black Gloss /
Black Glass**

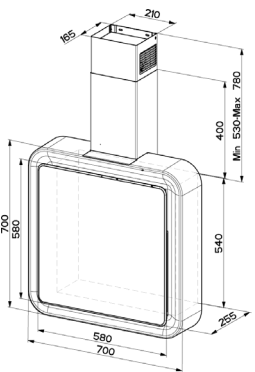

The hood can also be operated by using the controls on a Faber hob

**White/
White glass**

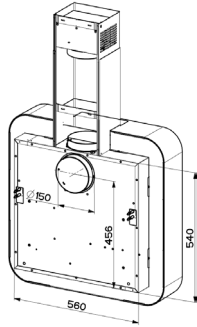

PYANA

PYANA ARIES WH A70 cod. 335.0541.003
PYANA ARIES BN/BK A70 cod. 335.0541.004

(optional) HOOD&HOB



FEATURES	PERFORMANCES	ACCESSORIES
Finish • Black Gloss / Black Glass • White / White glass	Speed 1 2 3 INT BOOST Air capacity IEC point 180 250 435 620 750 Pressure 210 280 490 520 550 Input 55 65 130 145 280 Noise level 40 45 57 66 70	Cod. 112.0540.783 Charcoal filter Cod. 112.0540.043 Remote control
Controls Squarcle touch		
Lighting LED light		
Grease filter Stainless steel cassettes dishwasher safe		
Ø of air outlet 150 mm / 120mm		
Width 700 mm		
Energy class A+		
Motors 2		

PYANA



NEW NAUTILUS TECHNOLOGY. Perfect, silent nature.



NAUTILUS
TECHNOLOGY

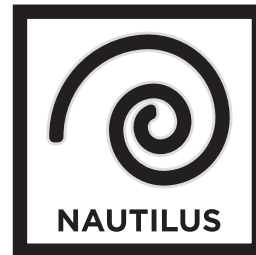

MORE POWER WITH LESS NOISE.

The NEW NAUTILUS blower is the latest evolution in FABER technology for ultra-thin vertical hoods. NEW NAUTILUS boosts extraction power by 30 m³/h, and reduces noise too. That means greater efficiency, with the same economic consumption as before.

MAXIMUM COMFORT AND ENERGY CLASS A.

NEW NAUTILUS occupies only 15 cm of space but guarantees maximum hood efficiency for amazing comfort in the kitchen. Silently!

NATURE IMPROVED BY TECHNOLOGY.

The basic design of NEW NAUTILUS is still inspired by the cross section of the nautilus shell, but now FABER has optimised the rotor thanks to advanced research into fluid dynamics and improved comfort and performance through other innovations.





reddot award 2017
winner

Dark grey matt - DG MATT



Old Copper - OC



Cross Titanium - CT



Dark Grey Concrete - DGC



Stainless steel - X



IMPROVING ON PERFECTION.

Faber's famous vertical hood is re-inventing its role as "window over the hob" by adopting the latest Nautilus technology. The new Nautilus motor not only improves performance but makes Talika an even more desirable addition to your kitchen by reducing noise yet again. Unprecedented comfort from a lightweight, ultra-thin hood now available in new finishes.

Award winning hood featuring the very latest in motor technology and designer finishes.

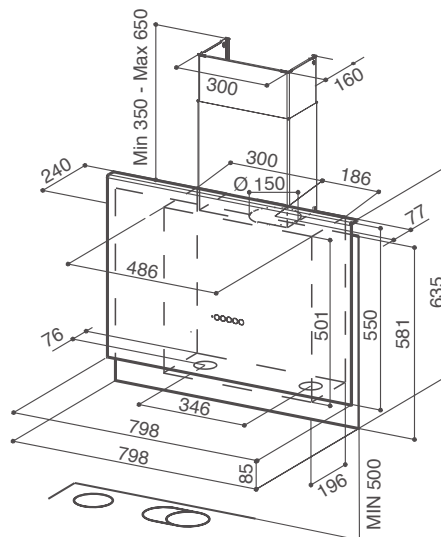

To be installed at a minimum distance from the hob of **50 cm**.

TALÌKA

TALÌKA OC A80 cod. 330.0540.784
TALÌKA CT A80 cod. 330.0540.785
TALÌKA DGC A80 cod. 330.0543.972

TALÌKA X A80 cod. 330.0543.971
TALÌKA DARK GREY CONCRETE A80 cod. 330.0540.786

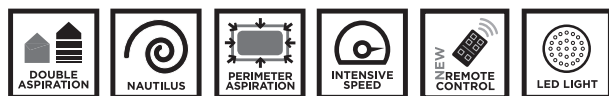

(optional)



FEATURES	PERFORMANCE	ACCESSORIES
Finish • Old copper • Cross titanium • Dark grey concrete • Stainless steel • Dark grey matt	Speed 1 2 3 INT Air capacity IEC point 200 300 410 560 Pressure 360 470 560 650	Cod. 112.0540.783 F22 Charcoal filter Cod. 112.0540.043 Remote control
Controls Squarcle touch	Input 100 110 120 135 Noise level 51 59 66 72	
Lighting LED lights		
Grease filter Cassettes dishwasher safe		
Ø of air outlet 150 / 120 mm		
Width 800 mm		
Energy class A		

Cream White



White Matt



Cameo Pink



Black Matt



Thalia with Chimney



Rear ducting and fresh matt colour options make this a popular choice.

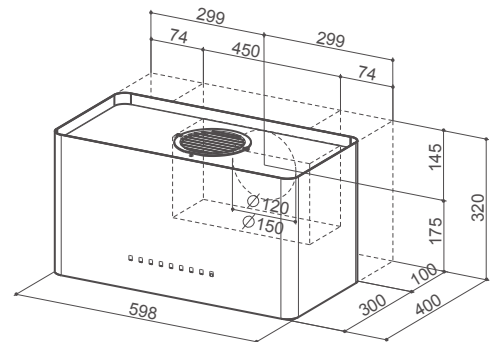

THALIA

THALIA WH MATT F60 cod. 110.0324.923
 THALIA PINK F60 cod. 110.0324.925

THALIA CREAM F60 cod. 110.0324.926
 THALIA BK MATT F60 cod. 110.0437.124



FEATURES	PERFORMANCES	ACCESSORIES
Finish · White matt · Cameo pink · Cream white · Black matt	Speed 1 2 3 INT Air capacity IEC point 280 420 560 650 Pressure 420 500 550 580	Cod. 112.0540.043 Cod. 112.0327.007 Remote control ENERGY Remote blower kit Cod. 112.0327.633 Chimney kit Wh matt Cod. 112.0329.961 Chimney kit Pink Cod. 112.0329.962 Chimney kit Cream Cod. 112.0437.743 Chimney kit Bk matt
Controls EVO feel touch	Input 190 230 255 270 Noise level 49 59 66 69	Cod. 112.0158.127 FHP8 Charcoal filter High Performance Cod. 112.0185.278 FLL8 Charcoal filter Long Lasting
Lighting Perimetral LED light		
Grease filter Cassettes dishwasher safe		
Ø of air outlet 150 / 120		
Width 600 mm		
Energy class B		

TWEET



Brand new in
the Faber range;
powerful and
great value.

Black Glass



**BRAND
NEW**

White glass

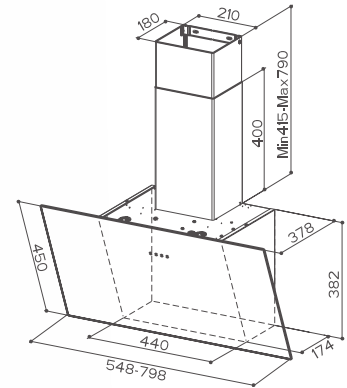

To be installed at a minimum
distance from the hob of **50 cm**.

TWEET

TWEET EG8 LED BK A80 cod. 330.0529.666
TWEET EG8 LED WH A80 cod. 330.0529.667

TWEET EG8 LED BK A55 cod. 330.0529.664
TWEET EG8 LED WH A55 cod. 330.0529.665



(optional)

FEATURES	PERFORMANCES	ACCESSORIES
Finish • Black glass • White glass	Speed 1 2 3 INT	Cod. 112.0158.127 Cod. 133.0301.599
Controls Touch control	Air capacity IEC point 310 480 620 700	FHP8 Charcoal filter High Performance
Lighting 2 LED lights	Pressure 380 465 490 510	Cod. 112.0252.439 Cod. 133.0272.534
Greas filter Cassettes dishwasher safe	Input 135 170 215 250	Recycling version kit WH
Ø of air outlet 150 / 120 mm	Noise level 52 61 67 70	Cod. 112.0252.442 Recycling version kit BK
Width 800 mm		Cod. 112.0185.278 FLL8 Charcoal filter Long Lasting
Energy class C		Cod. 133.0046.956 Internal Chimney Recirculating Kit



This uniquely shaped hood is designed to flow like a fabric veil; a truly eye-catching hood.

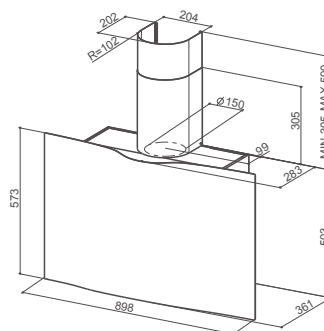

VEIL

VEIL WH MATT A90 cod. 110.0324.952

VEIL WH A90 cod. 110.0324.953

VEIL BK A90 cod. 110.0324.954

VEIL CONCRETE cod. 110.0393.869

VEIL TIBETAN SILVER cod. 110.0393.872



EVO
DIFFUSER



REMOTE
BLOWER



INTENSIVE
SPEED



LED LIGHT

(optional)



FEATURES	PERFORMANCES	ACCESSORIES
Finish • White matt • White • Black matt • Concrete • Tibetan silver	Speed 1 2 3 INT Air capacity IEC point 300 410 570 700 Pressure 420 490 530 550	Cod. 112.0327.007 ENERGY Remote blower kit
Controls Electronic	Input 190 230 255 270 Noise level 50 58 65 69	Cod. 112.0158.127 FHP8 Charcoal filter High Performance
Lighting 2 LED lights		Cod. 112.0185.278 FLL8 Charcoal filter Long Lasting
Grease filter Cassettes dishwasher safe		
Ø of air outlet 150 / 120 mm		
Width 900 mm		
Energy class A+		

White Matt



White - Chimney Finish: Stainless steel



Black Matt - Chimney Finish: Stainless steel



Limited Edition

Concrete - Chimney Finish: White Matt



Limited Edition

Tibetan silver - Chimney Finish: White Matt

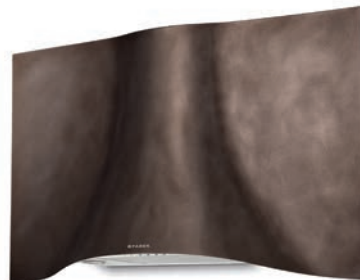



White glass

Black Glass



Classic glass wall hood in black or white.

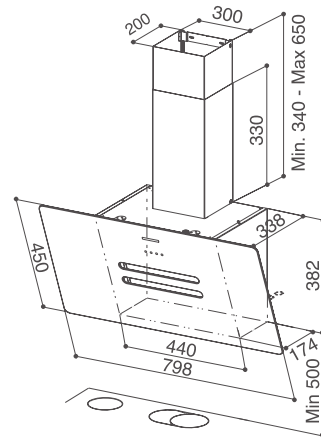

To be installed at a minimum distance from the hob of **50 cm**.

VANITY

VANITY EG6 BK A80 cod. 110.0371.518
VANITY EG6 WH A80 cod. 110.0371.519



(optional)

FEATURES	PERFORMANCES	ACCESSORIES
Finish • Black glass • White glass	Speed 1 2 3 INT Air capacity IEC point 290 430 510 550 Pressure 215 280 300 320 Input 90 105 125 140 Noise level 56 63 68 70	Cod. 112.0327.007 ENERGY Remote blower kit Cod. 112.0252.439 Recycling version kit WH Cod. 112.0252.442 Recycling version kit BK Cod. 112.0158.127 FHP8 Charcoal filter High Performance
Controls Touch control		Cod. 112.0185.278 FLL8 Charcoal filter Long Lasting Cod. 133.0301.599 Upper Chimney Recirculating Kit WH Cod. 133.0272.534 Upper Chimney Recirculating Kit BK Cod. 133.0046.956 Internal Chimney Recirculating Kit
Lighting 2 LED lights		
Grease filter Cassettes dishwasher safe		
Ø of air outlet 150 / 120 mm		
Width 800 mm		
Energy class C		

INTEGRATED HOODS

Discreet, rational, silent.
Built-in hoods reduce the aesthetic
impact of the hood in the kitchen
and integrate perfectly with the
cupboards. An essential tool that's
invisible to the eye.

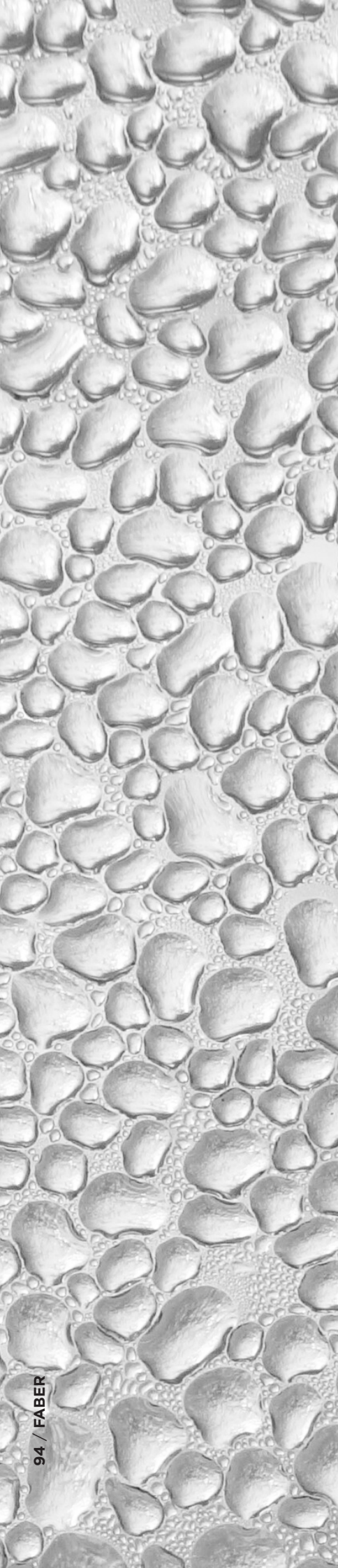

STEAM OFF SYSTEM TECHNOLOGY.

Total wellbeing. Zero condensation.



**STEAM OFF
TECHNOLOGY**

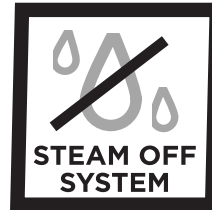

DUAL-ACTION AIR FLOW. GOODBYE CONDENSATION!

In parallel with normal extraction, SOS hoods inject carefully controlled helical and variable-geometry jets of air into the air flow. This creates a vortex that accelerates the air stream upwards, optimising the suction effect and capturing all cooking fumes and steam. The result? Goodbye condensation!

CONDENSATION-FREE INDUCTION HOODS. ANOTHER FABER EXCLUSIVE.

When you cook on an induction hob, you create a temperature differential between the hot air at the hob and the colder air under the hood. This disperses the steam, causing droplets of condensation to form all around the kitchen. FABER's exclusive SOS technology solves this problem once and for all.



ILMA

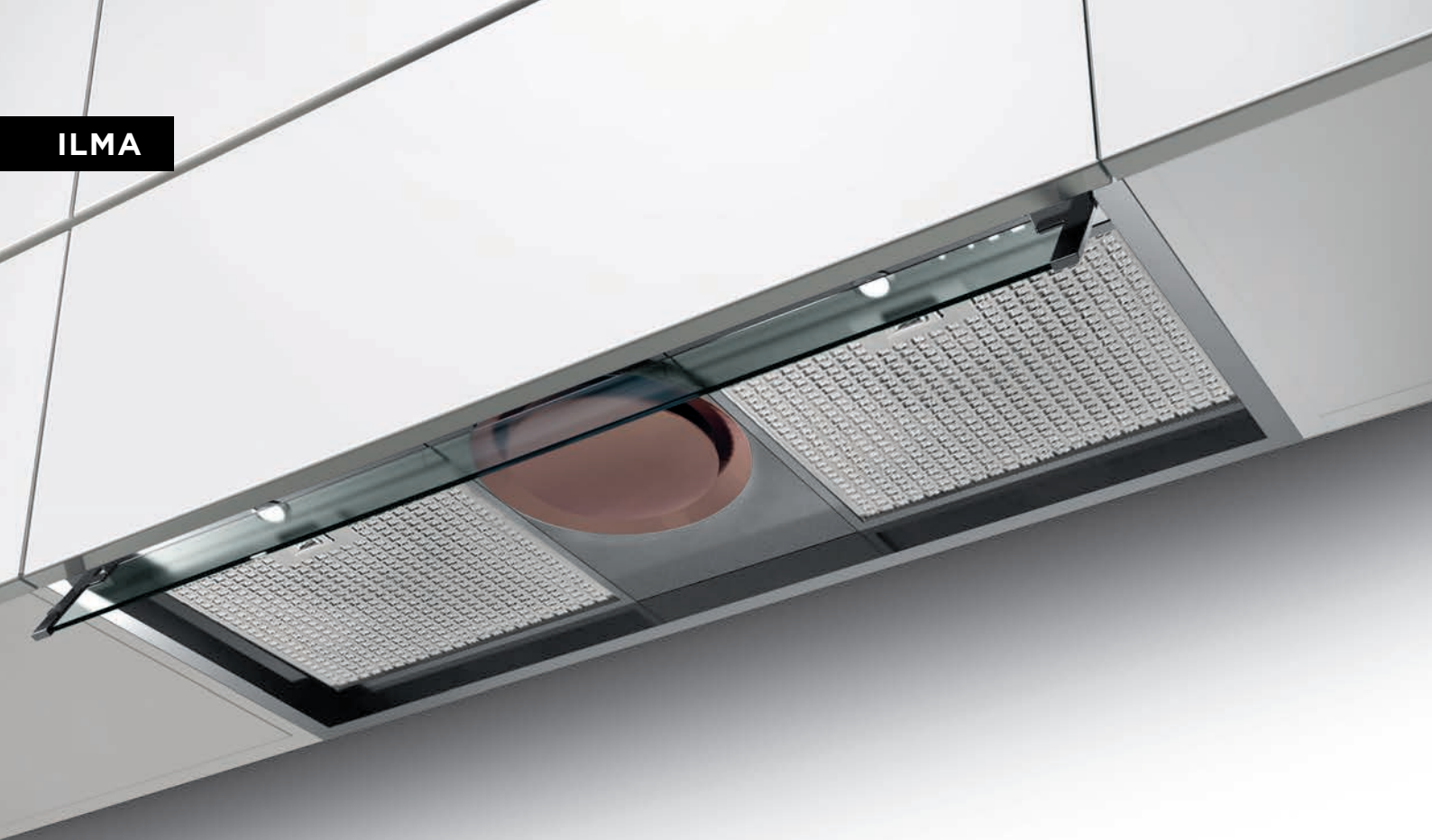

600 mm

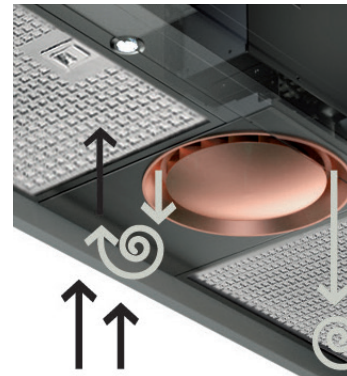

Designed specifically to eliminate the build-up of condensation on cabinets.

EXCLUSIVE, CONDENSATION-FREE COMFORT

With Steam Off System, the exclusive Faber technology, the hood not only sucks in but also emits air jets that create a vortical motion and acceleration and help to convey and capture the steam. This puts an end to condensation and its depositing under and around the hood!

DOUBLE AIR ACTION TO COMPLETELY ELIMINATE CONDENSATION.

The hood can also be operated by using the controls on a Faber hob

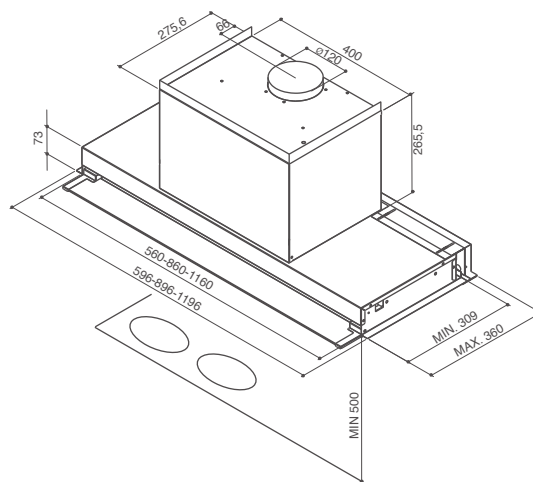

To be installed at a minimum distance from the hob of **50 cm**.

ILMA

ILMA X A60 cod. 305.0482.953
ILMA X A90 cod. 110.0456.294
ILMA X A120 cod. 305.0482.954



(optional)

HOOD&HOB

FEATURES	PERFORMANCE	ACCESSORIES
Finish • Stainless steel	Speed 1 2 3 INT	Cod. 112.0506.172
Controls Squarcle touch	Air capacity IEC point 195 270 378 455	F21 Charcoal filter Cod. 112.0540.043
Lighting LED lights	Pressure 240 250 260 270	Remote control
Grease filter Stainless steel cassettes dishwasher safe	Input 100 115 200 220	
Ø of air outlet 120 mm	Noise level 42 52 54 60	
Width 600 / 900 / 1200 mm		
Energy class A		

IN-LIGHT



Sleek, perimeter lighting accentuates the curved design.



The hood can also be operated by using the controls on a Faber hob

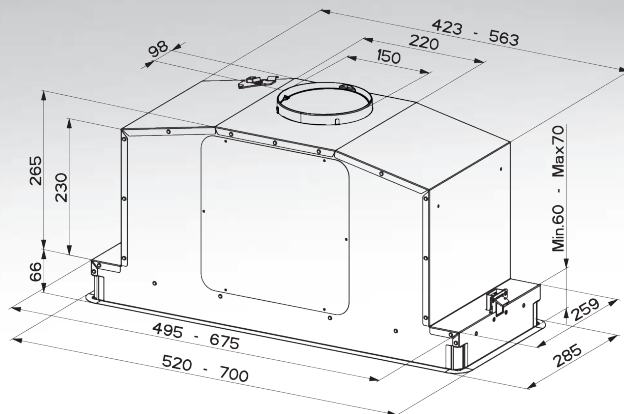

IN-LIGHT

IN-LIGHT EV8+ X A52 cod. 110.0456.213
IN-LIGHT EV8+ X A70 cod. 110.0456.215

IN-LIGHT EV8+ WH MATT A52 cod. 110.0456.216
IN-LIGHT EV8+ WH MATT A70 cod. 110.0456.218



HOOD&HOB

FEATURES	PERFORMANCE	ACCESSORIES
Finish • Stainless steel • White matt	Speed 1 2 3 INT	Cod. 112.0158.127
Controls Electronic LED	Air capacity IEC point 260 380 525 635	FHP8 Charcoal filter High Performance
Lighting Perimeter LED light	Pressure 390 500 510 530	Cod. 112.0185.278
Grease filter Cassettes dishwasher safe	Input 170 215 245 275	FLL8 Charcoal filter Long Lasting
Ø of air outlet 150 / 120 mm	Noise level 56 65 70 72	
Width 520 / 700 mm		
Energy class A		

SELF - START

Automatic hood control.



Forget about the hood, just enjoy the cooking!

A SPECIAL SENSOR SWITCHES THE HOOD ON AS SOON AS AIR TEMPERATURE REACHES 35°C.

A smart sensor activates your hood automatically whenever needed. Faber loves to make cooking easier and more enjoyable!

Class A energy efficiency, super-effective perimeter extraction plus an easy-to-clean panel to keep your kitchen looking great.

A TALENT FOR DESIGN TOO.

Only Faber offers you designer hood technology in a traditional canopy model.

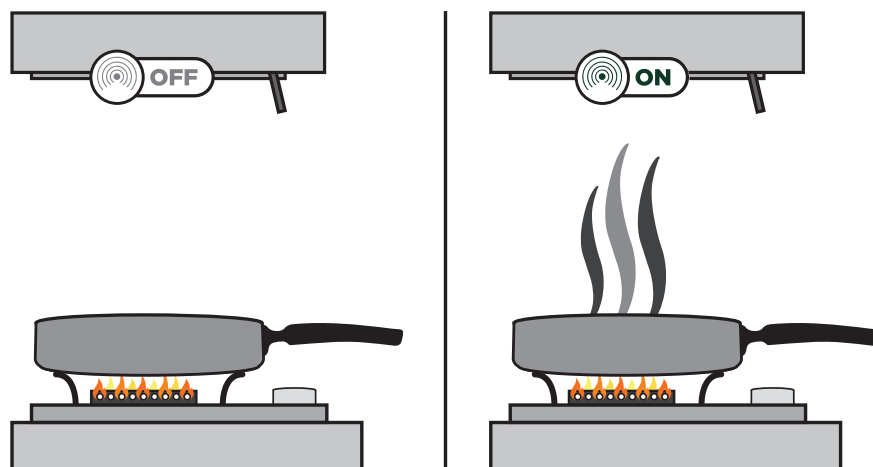

Sleek Stainless steel integrated hood with self-start technology.

SELF - START

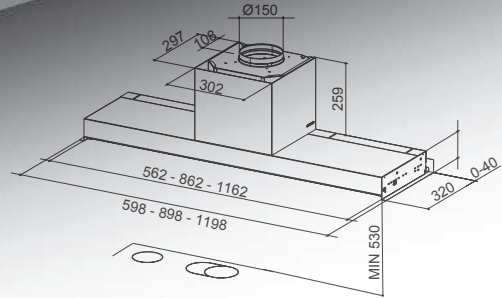

The hood can also be operated by using the controls on a Faber hob

To be installed at a minimum distance from the hob of **53 cm**.

IN-NOVA PREMIUM

IN-NOVA PREMIUM EV8+ X A60 cod. 110.0439.940
IN-NOVA PREMIUM EV8+ X A90 cod. 110.0439.951
IN-NOVA PREMIUM EV8+ X A120 cod. 110.0439.952



FEATURES	PERFORMANCE	ACCESSORIES
Finish • Stainless steel	Speed 1 2 3 INT	Cod. 112.0157.243
Controls Electronic SENSOR	Air capacity IEC point 280 420 570 670	F9 Charcoal filter Cod. 112.0540.043
Lighting 2 LED lights	Pressure 420 465 510 520	Remote control Cod. 112.0327.007
Grease filter Cassettes dishwasher safe	Input 175 220 255 270	Cod. 112.0185.276
Ø of air outlet 150 / 120 mm	Noise level 53 62 68 70	ENERGY Remote blower kit
Width 600 / 900 / 1200 mm		FLL9 Charcoal filter Long Lasting
Energy class A		

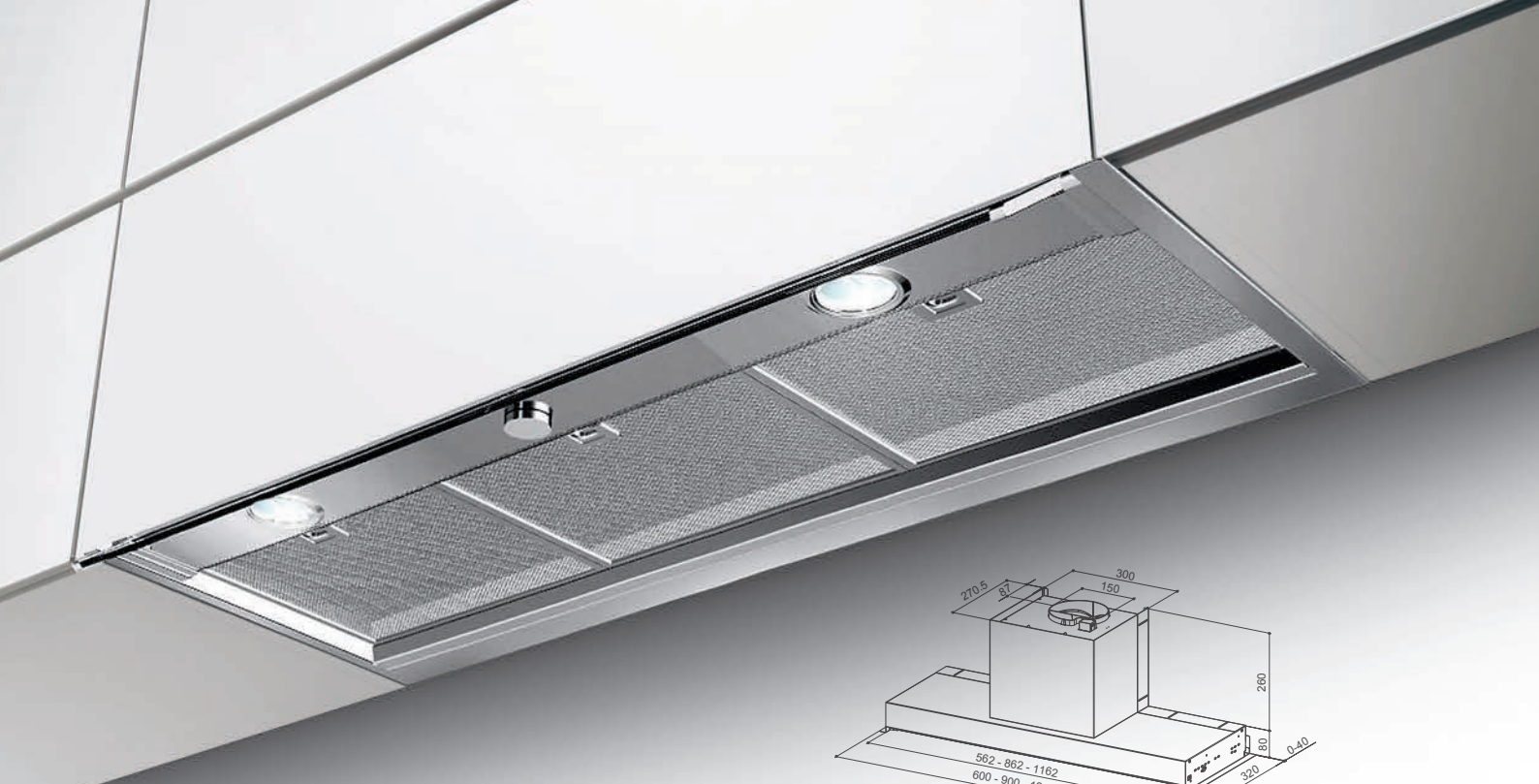

The glass visor protects the cabinets from grease vapour and steam.

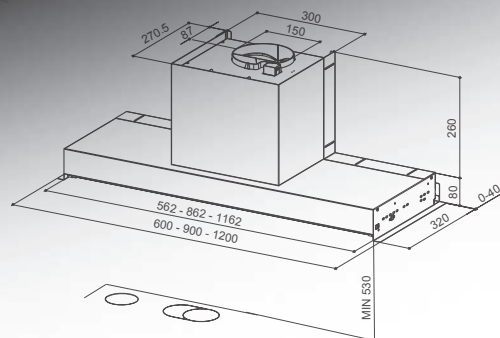

To be installed at a minimum distance from the hob of **53 cm**.

IN-NOVA SMART

IN-NOVA SMART X A60 cod. 110.0395.198
IN-NOVA SMART X A90 cod. 110.0395.382
IN-NOVA SMART X A120 cod. 110.0395.476



FEATURES	PERFORMANCE	ACCESSORIES
Finish · Stainless steel	Speed 1 2 3	Cod. 112.0067.944
Controls Pull out Knob	Air capacity IEC point 220 325 390	F3 Charcoal filter
Lighting 2 LED lights	Pressure 160 190 200	Cod. 112.0544.470
Grease filter Stainless steel cassettes dishwasher safe	Input 85 110 145	FLL3 Charcoal filter Long Lasting
Ø of air outlet 150 / 120 mm	Noise level 55 64 69	
Width 600 / 900 / 1200 mm		
Energy class D		

Our most popular built-in cooker hood with a super slim depth.



The hood can also be operated by using the controls on a Faber hob

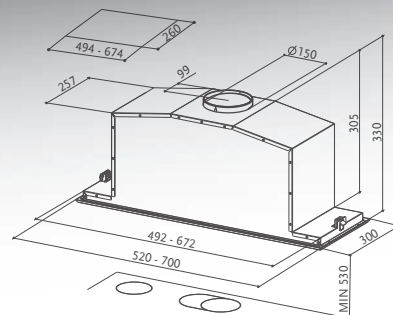

To be installed at a minimum distance from the hob of **53 cm**.

INCA LUX 2.0

INCA LUX 2.0 EV8 X A52 cod. 110.0327.652
 INCA LUX 2.0 EV8 X A70 cod. 110.0327.653



FEATURES	PERFORMANCE	520 mm	ACCESSORIES
Finish • Stainless steel	Speed	1 2 3 INT	Cod. 112.0540.043
Controls Electronic LED	Air capacity IEC point	300 460 590 660	Remote control
Lighting 2 LED lights	Pressure	350 440 480 510	Cod. 112.0327.007
Grease filter Cassettes dishwasher safe	Input	145 180 230 250	ENERGY Remote blower kit
Ø of air outlet 150 / 120 mm	Noise level	54 65 69 71	Cod. 112.0158.127
Width 520 / 700 mm	PERFORMANCE	700 mm	FHP8 Charcoal filter High Performance
Energy class B (700 mm) C (520 mm)	Speed	1 2 3 INT	Cod. 112.0185.278
	Air capacity IEC point	315 480 630 710	FLL8 Charcoal filter Long Lasting
	Pressure	340 450 480 510	
	Input	145 180 230 250	
	Noise level	52 62 68 70	



A sleek glass panel accentuates this stylish hood.

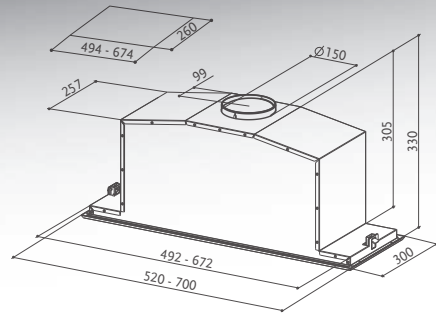

INCA LUX GLASS

INCA LUX EV8 X/WH A52 cod. 110.0356.481
 INCA LUX EV8 X/BK A52 cod. 110.0356.519

INCA LUX EV8 X/WH A70 cod. 110.0356.541
 INCA LUX EV8 X/BK A70 cod. 110.0356.558



(optional)

FEATURES	PERFORMANCE	520 mm	ACCESSORIES
Finish • Stainless steel / White glass • Stainless steel / Black glass	Speed	1 2 3 INT	Cod. 112.0327.007
Controls Electronic	Air capacity IEC point	300 460 590 660	ENERGY Remote blower kit
Lighting 2 LED lights	Pressure	350 440 480 510	Cod. 112.0158.127
Grease filter Cassettes dishwasher safe	Input	145 180 230 250	FHP8 Charcoal filter High Performance
Ø of air outlet 150 / 120 mm	Noise level	54 65 69 71	Cod. 112.0185.278
Width 520 / 700 mm	PERFORMANCE	700 mm	FLL8 Charcoal filter Long Lasting
Energy class B (700 mm) C (520 mm)	Speed	1 2 3 INT	
	Air capacity IEC point	315 480 630 710	
	Pressure	340 450 480 510	
	Input	145 180 230 250	
	Noise level	52 62 68 70	

*Not available for use with remote control.

A classic compact integrated
cooker hood.



**BRAND
NEW**

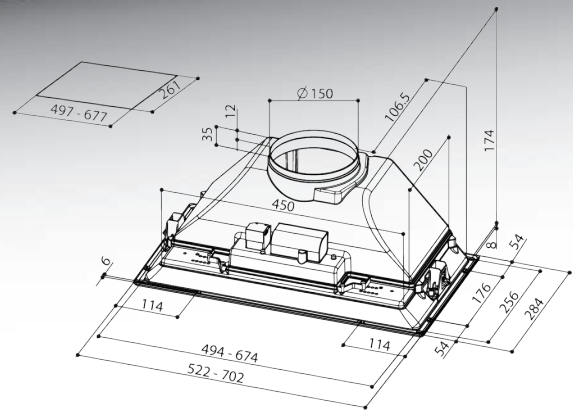

INCA SMART ICH

INCA SMART ICH X A52 cod. 305.0536.877

INCA SMART ICH X A70 cod. 305.0536.878



FEATURES	PERFORMANCE	ACCESSORIES
Finish • Stainless steel	Speed 1 2 3	Cod. 112.0067.944 F3 Charcoal filter
Controls Electronic	Air capacity IEC point 235 330 400	
Lighting 2 LED lights	Pressure 180 210 220	
Grease filter Cassettes dishwasher safe	Input 85 100 140	
Ø of air outlet 150 / 120 mm	Noise level 57 66 70	
Width 520 / 700 mm		
Energy class D		

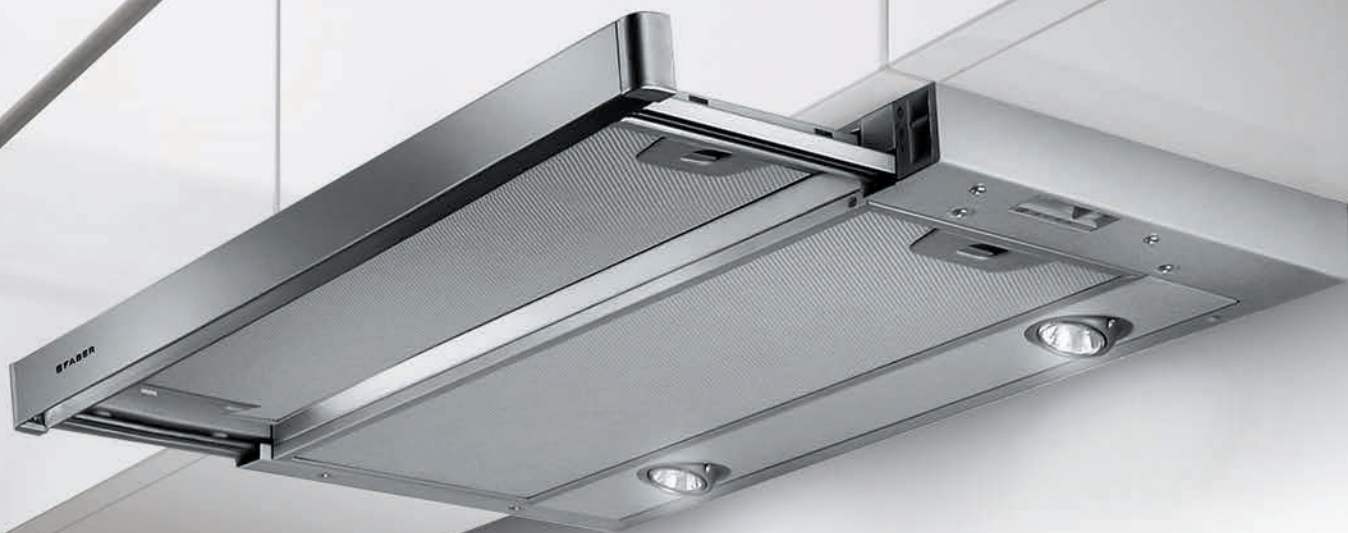

Telescopic action for an increased extraction area.

MAXIMA

MAXIMA EV8 LED AM/X A60 cod. 315.0534.352
 MAXIMA EV8 LED AM/X A90 cod. 315.0534.353

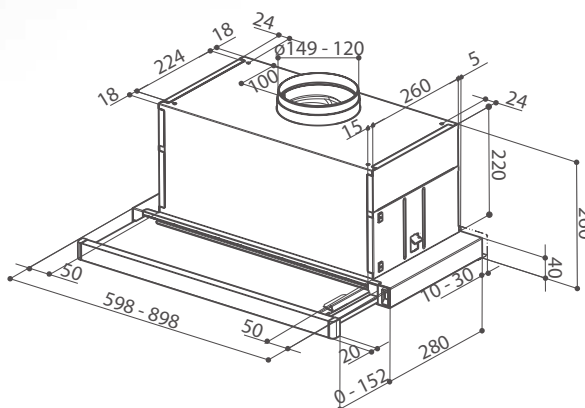

(optional)

FEATURES	PERFORMANCE	ACCESSORIES
Finish • Metal aluminium / Stainless steel handle	Speed 1 2 3	Cod. 112.0327.007
Controls Electromechanical	Air capacity IEC point 310 490 640	ENERGY Remote blower kit
Lighting 2 LED lights	Pressure 340 450 490	Cod. 112.0158.127
Grease filter Cassettes dishwasher safe	Input 145 180 250	FHP8 Charcoal filter High Performance
Ø of air outlet 150 / 120 mm	Noise level 51 61 67	Cod. 112.0185.278
Width 600 / 900 mm		FLL8 Charcoal filter Long Lasting
Energy class B		

Versatile, slimline and powerful.

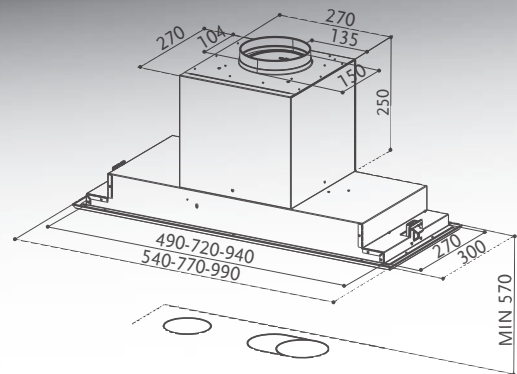

VICTORY 2.0

VICTORY 2.0 X A54 cod. 110.0357.399

VICTORY 2.0 X A77 cod. 110.0357.395

VICTORY 2.0 X A99 cod. 110.0357.341

To be installed at a minimum distance from the hob of **57 cm**.

Air outlet adjustable in 4 positions



(optional)

FEATURES	PERFORMANCES	ACCESSORIES
Finish · Stainless steel	Speed 1 2 3 INT	Cod. 112.0157.243
Controls Electronic LED	Air capacity IEC point 230 350 485 585	F9 Charcoal filter Cod. 112.0327.007
Lighting 2 LED lights (540-770 mm) 4 LED lights (990 mm)	Pressure 360 450 480 500	ENERGY Remote blower kit Cod. 112.0185.276
Grease filter Cassettes dishwasher safe	Input 135 170 215 250	FLL9 Charcoal filter Long Lasting
Ø of air outlet 150 / 120 mm	Noise level 50 61 67 70	
Width 540 / 770 / 990 mm		
Energy class C		

HOBS

NEW CONNECTION TECHNOLOGY.

New connections between technology and style.

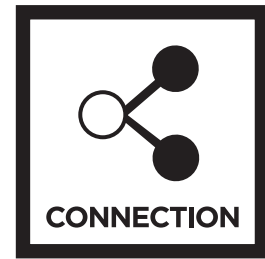

FABER HOBS ADD THAT FINISHING TOUCH TO YOUR KITCHEN

With hood controls integrated in the hob, the gestures of cooking and kitchen life become so much easier. Only FABER can make improvements with such contemporary style.

NEW COLLECTION, NEW CONNECTION

FABER has just added another three different-size models already able to integrate with 2018 Collection hoods.
 FCH63: a square hob with 2 small induction zones rings and a large hotplate.
 FCH84: a large, rectangular hob with 4 different cooking areas.
 FCH83: an elongated hob with 3 hotplates in line.

PERFECT HARMONY WITH A TOUCH OF GLAMOUR

FABER's three new induction hobs boast original, exclusive graphics with eye-catching, curved lines to give your kitchen a glamorous, contemporary look. When combined with the splendid F-light and Vertical hoods, newly designed for 2018, their elegant Graphite Grey finishes create exquisite matches in colour and style.

FABER CONNECTION: models equipped by connection technology with Faber induction hobs



560mm



The hood can be controlled via the hob

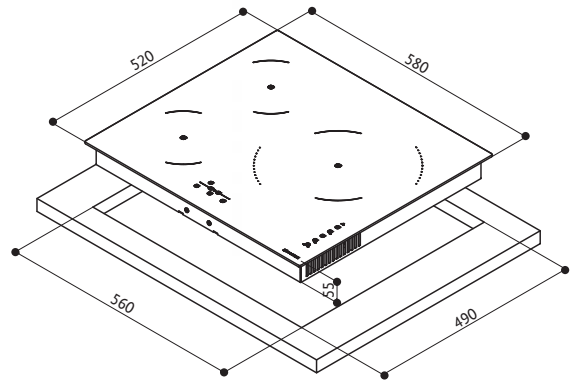

FCH63

FCH63 GR cod. 108.0536.628



HOOD&HOB

FEATURES	FUNCTIONS	POWER COOKING ZONE
Finish · Grey graphite glass RAL 7024	Power setting (9 stages)	
Product dimensions LxW (mm) 580x520	Timer min-max (1-99 minutes)	
Recess dimensions LxW (mm) 560x490	Booster (P)	
Induction zone 3	Auto switch off	
Controls Touch control	Over temperature protection	
Min-max pan size (mm) 110-265	Over current or voltage abnormality protection	
Power (W) 4900	Container detection system	
Voltage (V) 230	Automatic shutdown protection	
Frequency (HZ) 50/60	Power On indicator	
ADJUSTABLE ABSORPTION SETTING ON 3 POWER LEVELS (KW)		
	· 2,8	
	· 3,5	
	· 7,4	

560mm



The hood can be controlled via the hob

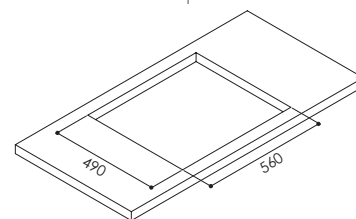
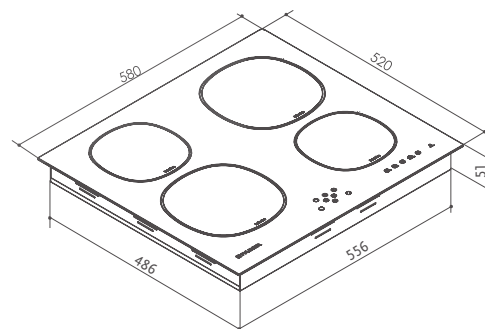

FCH64

FCH64 cod. 108.0456.299



HOOD&HOB

FEATURES	FUNCTIONS	POWER COOKING ZONE
Finish · Black glass	Power setting (9 stages)	1 Cooking zone 2300 W Ø 200 3000 W Booster 2 Cooking zone 1400 W Ø 160 3 Cooking zone 2300 W Ø 200 3000 W Booster 4 Cooking zone 1400 W Ø 160
Product dimensions LxW (mm) 580x520	Timer min-max (1-99 minutes)	
Recess dimensions LxW (mm) 560x490	Booster (P)	
Induction zone 4	Auto switch off	
Controls Touch control	Over temperature protection	
Min-max pan size (mm) 110-225	Over current or voltage abnormality protection	
Power (W) 7400	Container detection system	
Voltage (V) 230	Automatic shutdown protection	
Frequency (HZ) 50/60	Power On indicator	<div style="border: 1px solid black; padding: 5px; text-align: center;"> ADJUSTABLE ABSORPTION SETTING ON 3 POWER LEVELS (KW) </div>
	· 2,8	
	· 3,5	
	· 7,4	

760mm



The hood can be controlled via the hob

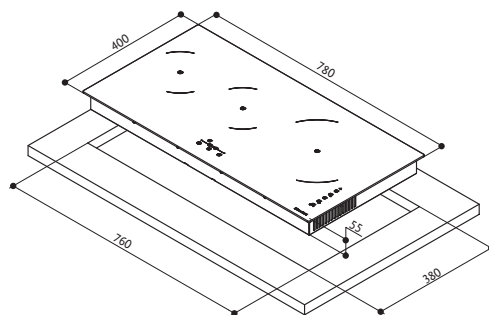

FCH83

FCH83 GR cod. 108.0536.630



HOOD&HOB

FEATURES	FUNCTIONS	POWER COOKING ZONE
Finish · Grey graphite glass RAL 7024	Power setting (9 stages)	1 Cooking zone 1400 W Ø 175 2000 W Booster Ø 175 <hr/> 2 Cooking zone 1400 W Ø 175 <hr/> 3 Cooking zone 2300 W Ø 215 3000 W Booster Ø 200
Product dimensions LxW (mm) 780x400	Timer min-max (1-99 minutes)	
Recess dimensions LxW (mm) 760x380	Booster (P)	
Induction zone 3	Auto switch off	
Controls Touch control	Over temperature protection	
Min-max pan size (mm) 110-265	Over current or voltage abnormality protection	
Power (W) 6400	Container detection system	
Voltage (V) 230	Automatic shutdown protection	
Frequency (HZ) 50/60	Power On indicator	
ADJUSTABLE ABSORPTION SETTING ON 3 POWER LEVELS (KW)		
	· 2,8	
	· 3,5	
	· 7,4	



750mm



The hood can be controlled via the hob

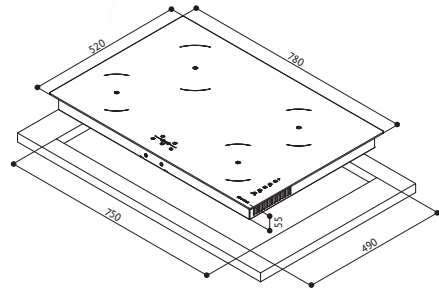

FCH84

FCH84 GR cod. 108.0536.629



HOOD&HOB

FEATURES	FUNCTIONS	POWER COOKING ZONE
Finish · Grey graphite glass RAL 7024	Power setting (9 stages)	1 Cooking zone 1200 W Ø 175 1400 W Booster 2 Cooking zone 2300 W Ø 215 3000 W Booster 3 Cooking zone 1400 W Ø 175 2000 W Booster 4 Cooking zone 1400 W Ø 175
Product dimensions LxW (mm) 780x520	Timer min-max (1-99 minutes)	
Recess dimensions LxW (mm) 750x490	Booster (P)	
Induction zone 4	Auto switch off	
Controls Touch control	Over temperature protection	
Min-max pan size (mm) 110-265	Over current or voltage abnormality protection	
Power (W) 7100	Container detection system	
Voltage (V) 230	Automatic shutdown protection	
Frequency (HZ) 50/60	Power On indicator	<div style="border: 1px solid black; padding: 5px; text-align: center;"> ADJUSTABLE ABSORPTION SETTING ON 3 POWER LEVELS (KW) </div> <ul style="list-style-type: none"> · 2,8 · 3,5 · 7,4



The hood can be controlled via the hob

880mm

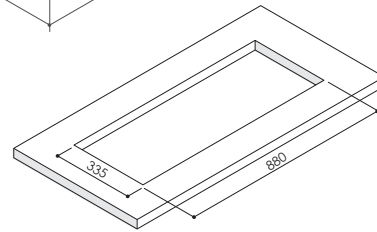
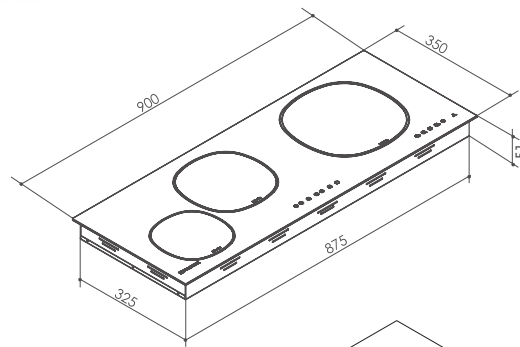

FCH93

FCH93 cod. 108.0456.300



HOOD&HOB

FEATURES	FUNCTIONS	POWER COOKING ZONE
Finish · Black glass	Power setting (9 stages)	1 Cooking zone 1400 W Ø 160 Booster
Product dimensions LxW (mm) 900x350	Timer min-max (1-99 minutes)	
Recess dimensions LxW (mm) 880x335	Booster (P)	3 Cooking zone 2500 W Ø 250 Booster
Induction zone 3	Auto switch off	
Controls Touch control	Over temperature protection	
Min-max pan size (mm) 110-265	Over current or voltage abnormality protection	
Power (W) 6700	Container detection system	
Voltage (V) 230	Automatic shutdown protection	
Frequency (HZ) 50/60	Power On indicator	<div style="border: 1px solid black; padding: 5px; text-align: center;"> ADJUSTABLE ABSORPTION SETTING ON 3 POWER LEVELS (KW) </div>
	· 2,8 · 3,5 · 7,4	

EXTERNAL MOTOR HOODS



EXTERNAL MOTOR INSTALLATION For truly silent extraction.

SILENCE INDOORS MEANS KEEPING THE NOISE OUTSIDE.

If your home has an extractor hood in the kitchen, living zone or any other indoor space, motor noise can now be completely eliminated. FABER's range of dedicated motorless hoods can be connected to an external motor installed outside the house. That means total silence throughout the living space indoors. Interior designers and hi-fi enthusiasts will be delighted with their new-found freedom to create dream environments.

External motor

A SMALL MOTOR THAT'S BIG IN COMFORT.

The external motor's compact dimensions and light weight (only 7 kg) make installation easy and allow the unit to be located in the ideal position outside the home. All that remains indoors is the stylish, elegant hood and, of course, all the benefits that come with it: the joy of living in perfect silence and the beauty of breathing pure air. Don't forget that external motors also solve so many problems of space and make hood installation possible in even the tightest spaces.

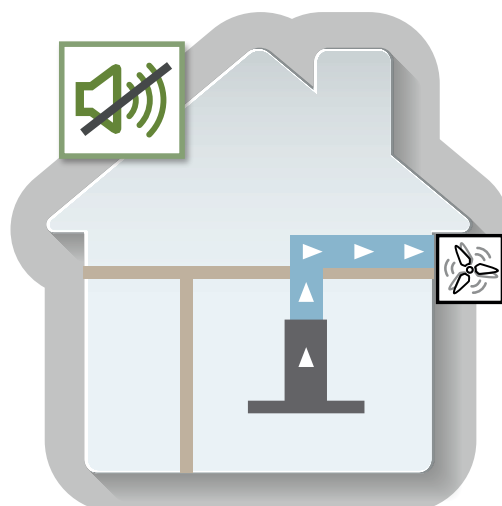

MISTRAL OUTDOOR

cod. 110.0365.067

Colour CREAM
Net weight 7 kg

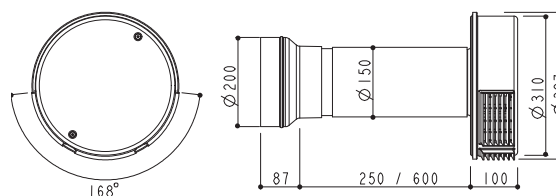

Remote Motor Hoods

CEILING



Heaven Glass 2.0

HEAVEN GLASS 2.0 WH 90 RB
cod. 110.0360.434



Heaven 2.0

HEAVEN 2.0 X 90 RB
cod. 110.0360.483

DOWNDRAFT DESIGN



Fabula

FABULA BK 90 RB
cod. 110.0360.581

WALL



Jolie

JOLIE WH 80 RB
cod. 110.0360.587
JOLIE BK 80 RB
cod. 110.0360.616



Stilo

STILO X 60 RB
cod. 110.0360.445
STILO X 90 RB
cod. 110.0360.447
STILO X 120 RB
cod. 110.0360.448

INTEGRATED



Stilnovo Lux

STILNOVO LUX X 60 RB
cod. 110.0360.516
STILNOVO LUX X 90 RB
cod. 110.0360.261
STILNOVO LUX X 120 RB
cod. 110.0360.353

ISLAND



Stilo Isola

STILO ISOLA X 90 RB
cod. 110.0360.352
STILO ISOLA X 120 RB
cod. 110.0360.353

ACCESSORIES

REMOTE MOTOR KIT

The silent pleasure of a remote motor.



THE JOY OF SILENT EXTRACTION WITH MORE FLEXIBLE KITCHEN DESIGN.

With a FABER hood, noise can be virtually eliminated by moving away its source - the motor and fan. FABER's Remote Motor Kit allows the motor to be removed from the hood and installed in another room, leaving your kitchen amazingly silent. And there's no risk of annoying your neighbours! Only Faber offers you the freedom to furnish your kitchen as you want and to enjoy the ultimate comfort, in line with the latest trends in urban green living.

THE SMART WAY TO TRANSFORM YOUR HOOD.

FABER's Remote Motor Kit lets you change the configuration of your hood by moving the motor away from the cooking area. A simple, practical and smart solution! The motor can be relocated with no installation or connection problems. The result? Less noise and greater comfort in the kitchen.

SIX METRES OF SILENCE.

FABER's Remote Motor Kit lets you move the hood's motor to another room, up to a maximum distance of 6 metres. Minimum noise and maximum comfort are guaranteed, not just in the kitchen but throughout the living area.

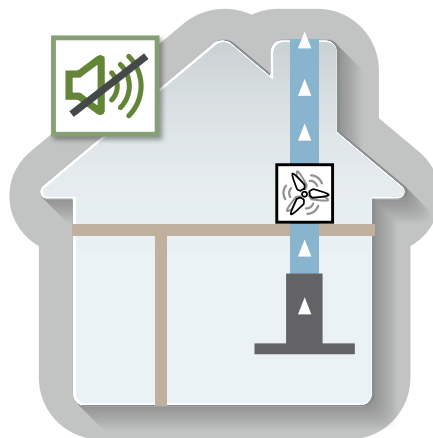
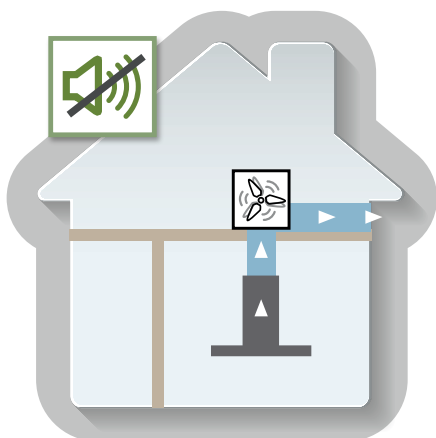
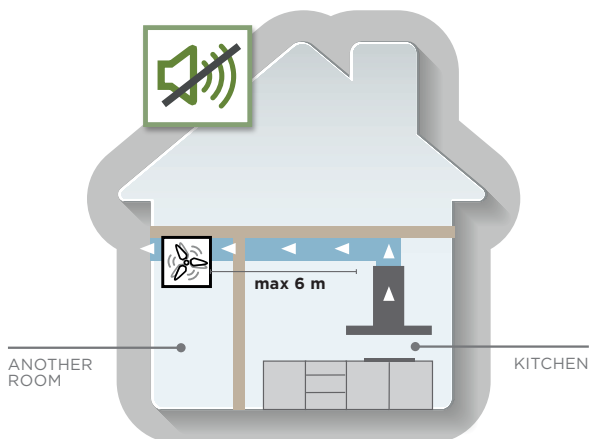

FLEXIBILITY MEANS FINDING THE RIGHT POSITION.

Thanks to its versatile design, the Remote Motor Kit can be installed in or moved to any of the positions illustrated here, so you can always find the best possible position for reducing noise.

Remote Motor Kit cod. 112.0327.007

The Remote Motor Kit is available with most FABER hoods.

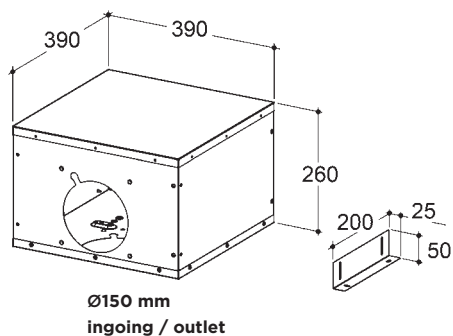
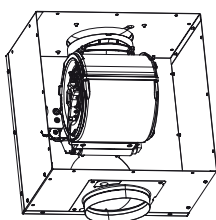

CHLOE REAR DUCT KIT

CHLOE REAR DUCT - OLD METAL
cod. 112.0490.249

CHLOE REAR DUCT - OLD COPPER
cod. 112.0490.250

CHLOE REAR DUCT - CAST IRON
cod. 112.0490.261

CHLOE REAR DUCT - OLD BRASS
cod. 112.0490.262

CHLOE REAR DUCT - DG MATT
cod. 112.0490.263

CHLOE REAR DUCT - CG MATT
cod. 112.0490.264

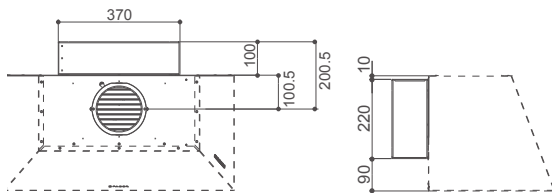

The kit is matched to the color of the hood

SLIM AIR-DUCT SYSTEM Ø 150 MM OR EQUIVALENT

ROUND TO RECTANGULAR ADAPTER 220x90mm
cod. 112.0459.429

Round to rectangular adapter 220x90 mm

- Heaven 2.0 Slim
- Heaven Glass 2.0 Slim
- High-Light

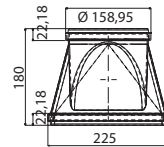

RECYCLING VERSION KIT

RECYCLING VERSION KIT WH cod. 112.0252.439

- Cocktail WH
- Cocktail XS WH
- Vanity WH

RECYCLING VERSION KIT BK cod. 112.0252.442

- Cocktail BK
- Cocktail XS BK
- Vanity BK

RECYCLING VERSION KIT X cod. 112.0327.632

- Jolie
- Northia
- City
- Daisy B



REMOTE CONTROL

REMOTE CONTROL 6T SQUARE cod. 112.0540.043

- Chloe
- Corinthia Isola
- Cylindra Gloss Plus
- Cylindra Isola
- Fabula Plus
- Grexia
- Ilma
- Inca Lux 2.0
- Onyx-T
- Pyana
- T-Light Isola
- Talika
- Thalia



NEW

F-LIGHT DUCTING KIT

F-LIGHT DUCTING KIT cod. 112.0169.216

- Lybra Plus
- Nest Plus
- Zoom Plus
- Vanilla Plus

Ø 150 mm - length 1 meter



AIRLANE DUCTING KIT cod. 112.0542.875

- Belle
- Belle Plus
- Celine
- Celine Plus
- Glow
- Glow Plus
- Odette
- Odette Plus



NEW

CERAMIC FILTER

GALILEO LONG LASTING CHARCOAL FILTER H100
cod. 112.0548.448

- Galileo



GALILEO LONG LASTING CHARCOAL FILTER H60 cod.
112.0548.447

- Galileo



RECYCLING KIT

RECTANGULAR DUCT RECIRCULATING KIT
cod. 112.0470.541

- Fabula Plus*

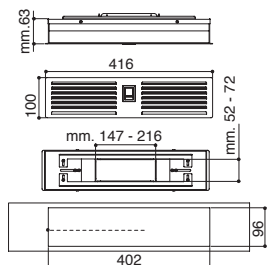

NOTE
To be purchased in addition
or as an alternative to the
Charcoal filter

RECTANGULAR DUCT CHARCOAL FILTER
cod. 112.0472.396

NOTE
Long Lasting
multi-layer filter
to combine with
cod. 112.0470.541



REMOTE BLOWER KIT

REMOTE BLOWER KIT ENERGY
cod. 112.0327.007

- Chloè
- Cylindra Isola
- Daisy B
- Heaven 2.0
- Heaven Glass 2.0
- Inca Lux 2.0
- Inca Lux Glass
- In-Nova Premium
- Jolie
- Maxima
- Stilo EV8
- Stilo Isola/SP
- Thalia
- Vanity
- Veil

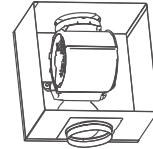

REMOTE BLOWER KIT FABULA
cod. 112.0327.008

- Fabula Plus

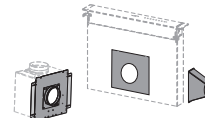

GALILEO INSTALLATION KIT

GALILEO COMPLETE RECIRCULATING KIT 60H
cod. 112.0540.730

- Galileo

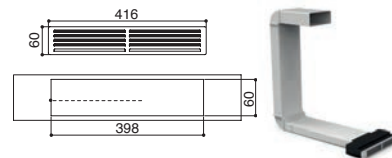

GALILEO COMPLETE RECIRCULATING KIT 100H
cod. 112.0540.781

- Galileo

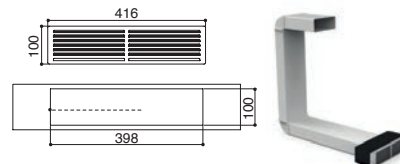

CHIMNEYS

**UPPER
CHIMNEY KIT H990 X** cod. 112.0157.252

- Stilo RB

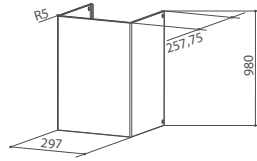

**UPPER
CHIMNEY KIT: H990 D370** cod. 112.0157.267

- Cylindra Isola X

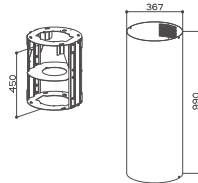

CHIMNEY KIT THALIA WH MATT cod. 112.0327.633

CHIMNEY KIT THALIA PINK cod. 112.0329.961

CHIMNEY KIT THALIA CREAM cod. 112.0329.962

CHIMNEY KIT THALIA BK MATT cod. 112.0437.743

- Thalia

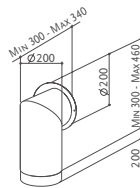

EXTRA HIGH CHIMNEY KIT: A500 + A500 X
cod. 112.0250.289

- City
- Daisy B
- Jolie
- Jolie RB
- Northia

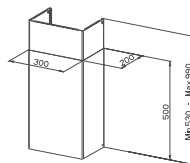

EXTRA HIGH CHIMNEY KIT: A500 + A500 BK
cod. 112.0250.290

- Black Tie BK
- Cocktail BK
- Cocktail XS BK
- Vanity BK

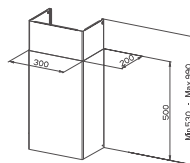

CHIMNEY RECYCLING KIT

THIS IS TO BE INSTALLED WHEN YOUR HOOD IS BEING USED IN RECYCLING MODE AND HAS A CHIMNEY PIECE ATTACHED.

INTERNAL CHIMNEY RECIRCULATING KIT
cod. 133.0046.956

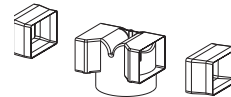

UPPER CHIMNEY RECIRCULATING KIT WH
cod. 133.0301.599

- Cocktail WH
- Vanity WH



UPPER CHIMNEY RECIRCULATING KIT BK
cod. 133.0272.534

- Cocktail BK
- Cocktail XS BK
- Vanity BK



UPPER CHIMNEY RECIRCULATING KIT X
cod. 133.0195.967

- City
- Daisy B
- Jolie
- Northia



NOTE
All Upper Chimney Recirculating Kits need a Internal Chimney Recirculating Kit cod.133.0046.956.

CHARCOAL FILTERS LONG LASTING



Multi-layer filter, it guarantees a double filtration and an optimal air cleanliness, it has a duration of up to 3 years.

FLL3 KIT 2.C.A. LONG LASTING
cod. 112.0544.470

- Inca Smart
- In-Nova Smart



FLL18-90 CHARCOAL FILTER 90CM cod. 112.0471.608

FLL18-120 CHARCOAL FILTER 120CM cod. 112.0471.609

- Heaven 2.0 Slim
- Heaven Glass 2.0 Slim
- High-Light



FLL8 LONG LASTING CHARCOAL FILTER
cod. 112.0185.278

- Arkea Plus
- Belle
- Belle Plus
- Black Tie
- Carrè
- Celine
- Celine Plus
- Cocktail
- Cocktail XS
- Daisy B
- Glam-Light
- Glow
- Glow Plus
- Grèxia
- Heaven 2.0
- Heaven Glass 2.0
- In-Light
- Inca Lux 2.0
- Inca Lux Glass
- Jolie
- Lithos
- Lybra Plus
- Maxima
- Nest Plus
- Odette
- Odette Plus
- Thalia
- Vanity
- Veil
- Zoom Plus

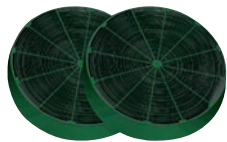

CHARCOAL FILTERS HIGH PERFORMANCE

High-efficiency filter, it guarantees more than 80% filtration capacity of intake fumes and a duration of up to 6 months.

FHP8 HIGH PERFORMANCE CHARCOAL FILTER
cod. 112.0158.127

- Arkea Plus
- Belle
- Belle Plus
- Black Tie
- Carrè
- Celine
- Celine Plus
- Cocktail
- Cocktail XS
- Daisy B
- Glam-Light
- Glow
- Glow Plus
- Grèxia
- Heaven 2.0
- Heaven Glass 2.0
- In-Light
- Inca Lux 2.0
- Inca Lux Glass
- Jolie
- Lithos
- Lybra Plus
- Maxima
- Nest Plus
- Odette
- Odette Plus
- Thalia
- Vanity
- Veil
- Zoom Plus



FLL9 LONG LASTING EASY CUBE CHARCOAL FILTER
cod. 112.0185.276

- Corinthia Isola
- Cylindra Isola
- In-Nova Premium
- Onyx-T
- Stilo/SP
- Stilo Isola/SP
- T-Light Isola
- Victory

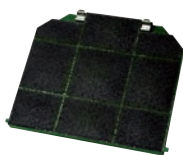

FLL12 FABULA CHARCOAL FILTER cod. 112.0261.258

- Fabula Plus



CHARCOAL FILTERS

Filter composed by a combination of charcoals and it should be replaced every 2-3 months.

F3 SMILE CHARCOAL FILTER cod. 112.0067.944

- Inca Smart
- In-Nova Smart

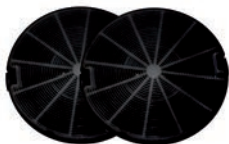

F9 263X237 CHARCOAL FILTER cod. 112.0157.243

- Corinthia Isola
- Cylindra Isola
- In-Nova Premium
- Onyx-T
- Stilo/SP
- Stilo Isola/SP
- T-Light Isola
- Victory



F21 CHARCOAL FILTER cod. 112.0506.172

- Ilma



F22 KIT C.A. NAUTILUS cod. 112.0540.783

- Glam-Fit
- Pyana
- Talika



FHP13 SKYLIFT HIGH PERFORMANCE CHARCOAL FILTER cod. 112.0329.927

- SkyLift



FHP14 SKYPAD HIGH PERFORMANCE CHARCOAL FILTER cod. 112.0329.928

- SkyPad 2.0



CHOOSING THE RIGHT HOOD

The necessary extraction capacity is determined by the volume of the kitchen. An effective hood changes the air of the kitchen 10 times per hour. A powerful motor is quieter and uses less energy because it is effective at low speeds.

-A hood does not create noise disturbance if its capacity is sufficient without exceeding 55 dB(A) of sound power.

-A powerful motor can be efficient even at lower, quieter speeds.

¹ Fan Handbook - F. Bleier 1998

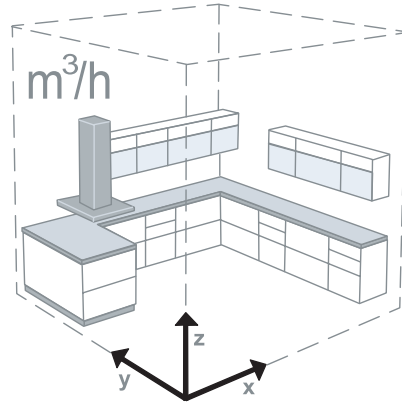

$$\text{EFFECTIVENESS} = \text{kitchen m}^2 \times \text{kitchen height} \times \text{10 changes of air}$$

Example: A 15 m² kitchen which is 3 m tall requires a hood which aspirates at least 450 m³/h. Infact: 15 m² x 3 m x 10 = 450 m³/h
Now consult the performance table found in the product catalogue.

The hood is efficient if an equal or higher capacity value is found in one of the speed columns.

Speed	1	2	3	4	INT
Air capacity IEC point	110	195	260	313	430
Pressure	-	-	-	-	-
Input	30	45	55	70	100
Noise level	48	53	58	62	69

INSTALLATION

Proper installation begins with an inspection. When choosing a hood, you should know:

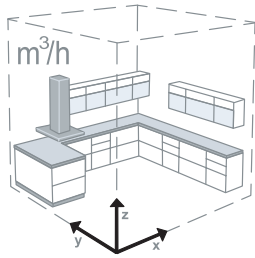

Kitchen volume (which determines the necessary aspiration capacity). See section "Choosing the right hood."

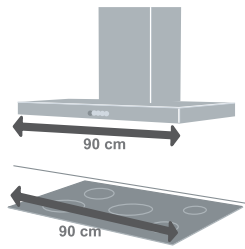

Length of the cooking top (the hood is generally as long as the cooking top area).

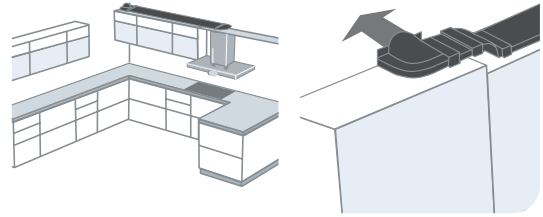

The position and distance of the exit hole (very long and very curved right-angled tubes limit hood efficiency).

Installation distance

The hood is to be installed at a minimum distance of 65 cm from the cooking top, except for particular models where is specified in the technical drawing and instructions manual.

ATTENTION: the product guarantee will not be considered valid if this distance is not respected. The hood may not reach declared performance levels if the distance from the cooking top exceeds 75 cm. Some vertical-installation models (ex. Jolie) are to be installed lower. Check the product's technical manual.

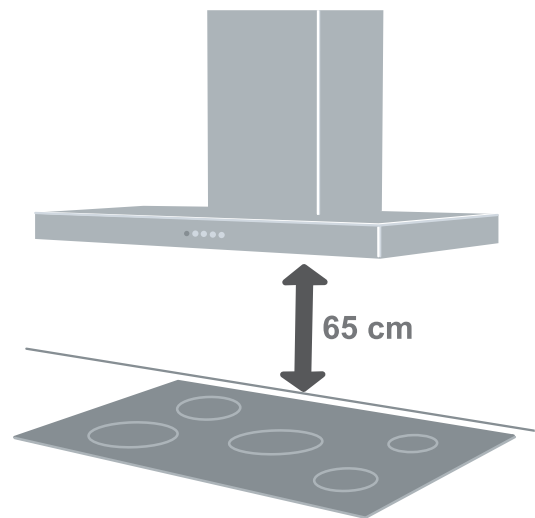

Inspection

- 1 - Turn on the motor
 - 2 - Switch on the lights
- If the hood is an extraction hood, verify that it is properly connected to the exit tubing.
If the hood is a filtering hood, verify that the Charcoal filters have been inserted.

First cleaning

- Remove the protective films
- Remove impurities with a damp sponge and a small amount of neutral soap
- Rinse with a damp cloth
- Dry with a soft cloth. If the hood is in Stainless steel, continue with a steel glaze
- You can give Stainless steel hoods a protective treatment with the Faber Clin&Clin tissue



Faber hoods are easy to install because they have EASY CUBE:

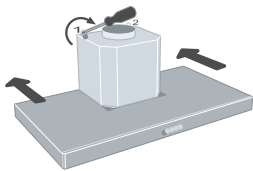

Hang the hood

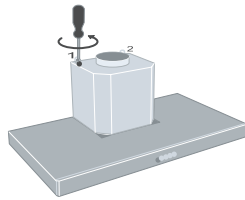

Align

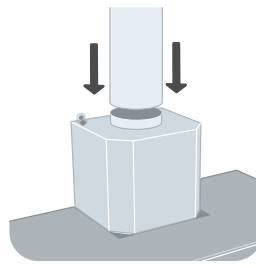

Connect tubing

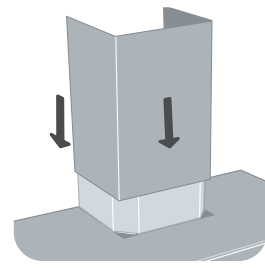

Insert the chimney

USE AND MAINTENANCE

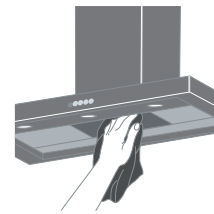

Switch on the hood a minute before cooking begins to create air flow that channels fumes and steam toward the aspiration surfaces.
If necessary, leave the hood switched on even after cooking is finished so that all steam and odours can be properly aspirated.

- Wash the metal anti-grease filters by hand or in the dishwasher every two months¹
 - Replace synthetic anti-grease filters every two months
 - Regular filter maintenance guarantees efficient hood use
- ATTENTION:** grease deposited on the filters is inflammable: be sure to perform regular maintenance
- ¹ These intervals of time refer to a regular use of the hood, approximately 3 hours per day

HOOD CLEANING

- Remove impurities with a damp sponge and a small amount of neutral soap²
 - Rinse with a damp cloth
 - Dry with a soft cloth, if the hood is in Stainless steel, follow the steel brushing
 - Clean the internal hood conduit once a year
- ² Acid-based cleaning products can damage hood surfaces

ANTI-ODOURS FILTERS

Long lasting



3
YEARS
MAX

Faber has developed a new, re-usable active carbon filter. Thanks to the multi-layer technology, the Long Lasting filter further increases filtration efficiency, with the double layer using an initial pre-filtration to capture the largest particles, and a second, more concentrated filtration to guarantee optimal air cleanliness. The filter can be washed in the dishwasher every 3-4 months¹, for a maximum of 3 years and dries at room temperature in a vertical position to allow the water to drain out. Alternatively, it can be placed in an oven at 50°C.

¹ Normal use cooker hood, by around 3 hours per day

High performance

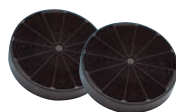

6
MONTHS
MAX

High-efficiency filter with a highly-concentrated carbon micro-granular structure that can guarantee more than 80% filtration capacity of intake fumes and a duration of up to 6 months, double that of a normal Charcoal filter, making for economic savings of more than 20%.

CERAMIC FILTER

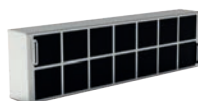

Innovative Charcoal filter that can be regenerated in the oven at 200° every 2-3 months and allows to reach high absorption efficiency.

QUALITY AND SAFETY

Faber hoods benefit from 60 years of competence in the treatment of kitchen air

- We were the first in the kitchen hood sector to obtain an ISO 9001 company quality system certificate.
- System integrated with Quality, Safety and Environment certified by SGS respecting the ISO 9001:2000, OHSAS 18001 and ISO 14001 norms.
- We have received the SGS Excellence Certificate, the absolute first in the world, number 001.
- All Faber hoods conform to European safety standards (EC mark of conformity), and have also been certified by the IMQ, a reliable, independent organisation further guaranteeing clients on quality (IMQ mark of security).

FABER HOODS ARE DESIGNED FOR SAFETY

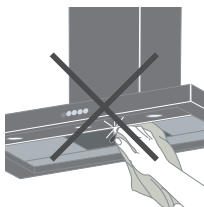

Hammered internal edges and tempered glass to avoid risks of cutting.

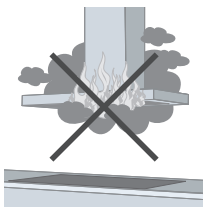

Thermo-protected motors and self-extinguishing plastics help avoid any risk of fire. Electronics are solid state, cables and connections are all placed correctly to avoid electric shock or dangerous sparks.

All Faber hoods have undergone safety and performance tests.

Aspiration and noise capacity have been measured according to standard norms:

- EN 61591
- EN 60704-3

unique specifications for surveying kitchen hood performance.

ATTENTION: Comparisons between different brand hoods should be carried out on complete data obtained according to these standards.

The Faber laboratory is NEMKO and IMQ certified.

NEED HELP?

Kitchenex are Faber's sole approved supplier for the UK. If you would like any further information, please call us on landline number.

kitchenEx[®]

All Faber products are sold with a 2-year guarantee, covering parts and labour. Defects caused by incorrect installation are not covered by the warranty.

Call 0114 399 8672 for a brochure or more information

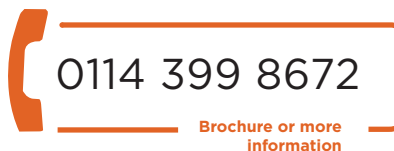

Call 0845 548 3132 for parts, servicing and warranty

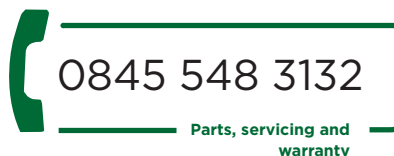

SPECIAL FINISHES

The images are indicative only and are not fully representative of the product finish.



Black Gloss
GLOW
GLOW PLUS
PYANA



White
GLOW
GLOW PLUS
PYANA

LITHOS



Old Copper
CHLOË
TALÌKA



Old Metal
CHLOË



Gold
BELLE
BELLE PLUS

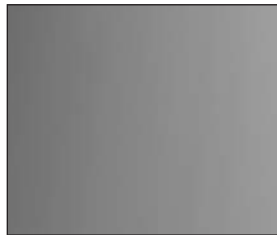

Grey matt
BELLE
BELLE PLUS
ODETTE
ODETTE PLUS

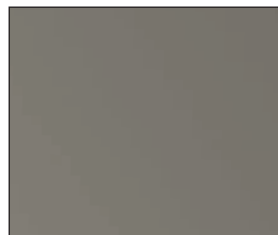

Country Grey Matt
CÉLINE
CÉLINE PLUS
CHLOË

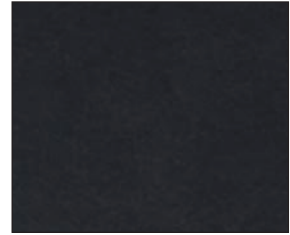

Dark Grey Matt
CHLOË
TALÌKA

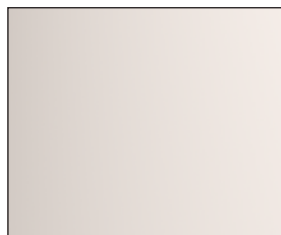

Warm white
Cèline
CÉLINE PLUS



Black matt
ODETTE
ODETTE PLUS

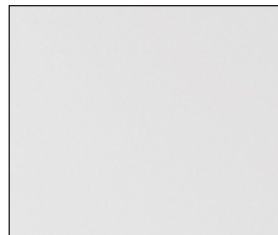

White Matt
T-LIGHT ISOLA
THALIA
VEIL
CORINTHIA ISOLA

HIGH-LIGHT
IN-LIGHT
LITHOS



Light Grey Stoneware
GRÈXIA

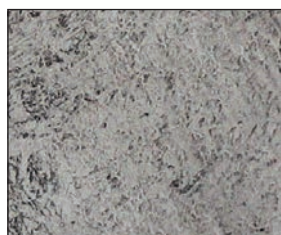

Dark grey concrete
TALÌKA

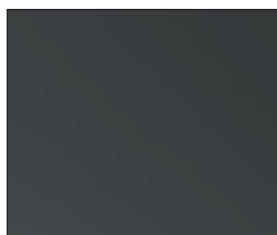

Cast iron
CHLOË



Dark Grey Stoneware
GRÈXIA



Concrete
LITHOS
VEIL

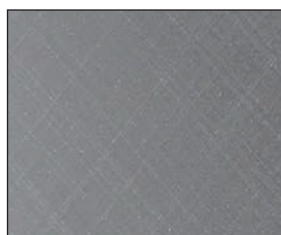

Cross titanium
TALÌKA

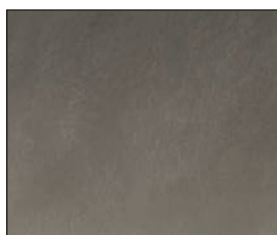

Old brass
CHLOË

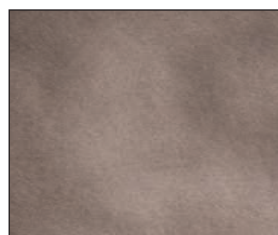

Tibetan Silver
PAREO PLUS
VEIL

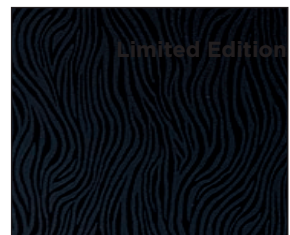

Zebra-Striped Glass
LYBRA PLUS

Limited Edition

Limited Edition

Faber UK 

www.faberhoods.co.uk



Faber Hoods are exclusively supplied in the UK by KitchenEX Ltd.

KitchenEX Ltd
MBP5, Meadowhall Business Park,
Carbrook Hall Road,
Sheffield, S9 2EQ

0114 399 8672
office@kitchenex.co.uk
www.faberhoods.co.uk